

STIHL MS 290, 310, 390

2004-11

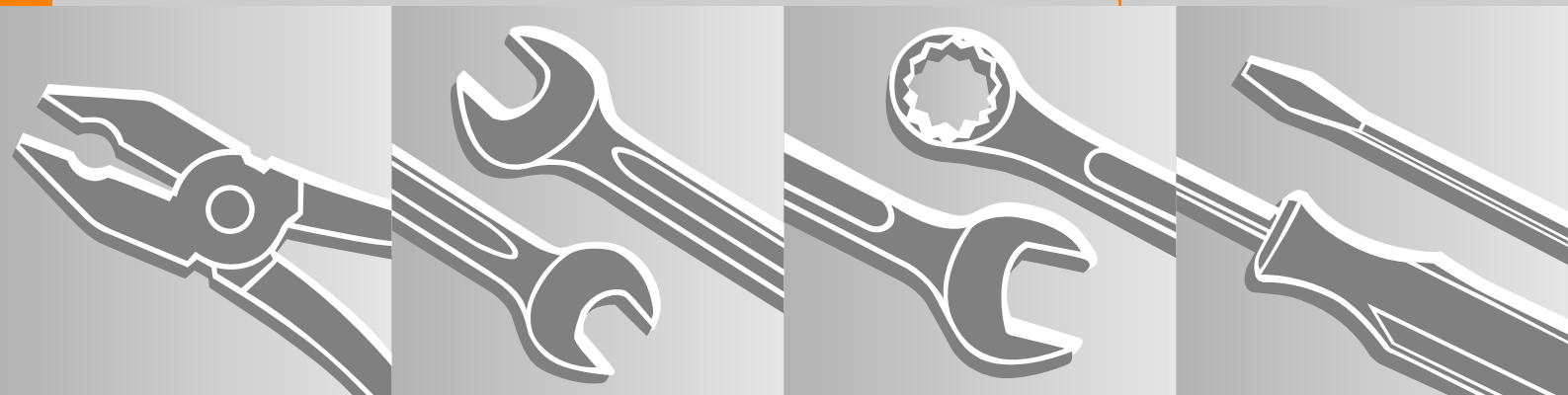

Contents

1.	Introduction	2	6.5	Removing and Installing the Engine	30	10.	Chain Lubrication	60
			6.5.1	Cylinder	31	10.1	Pickup Body/ Suction Hose	60
2.	Safety Precautions	3	6.5.2	Piston	33	10.2	Valve	61
			6.6	Piston Rings	35	10.3	Tank Cap	62
			6.7	Crankshaft	35	10.4	Oil Pump	62
3.	Specifications	4				10.4.1	Removing and Installing	62
3.1	Engine	4	7.	Ignition System	36	10.4.2	Servicing	63
3.1.1	Engine (USA only)	4	7.1	Ignition Module	37			
3.2	Fuel System	5	7.1.1	Ignition Timing	37	11.	Fuel System	64
3.3	Ignition System	5	7.1.2	Removing and Installing	37	11.1	Air Filter	64
3.4	Chain Lubrication	5	7.1.3	Testing the Ignition Module	39	11.2	Carburetor	65
3.5	Tightening Torques	6	7.2	Spark Plug Boot	40	11.2.1	Removing and Installing	65
4.	Troubleshooting Chart	7	7.2.1	Ignition Lead	41	11.2.2	Leakage Test	66
4.1	Clutch, Chain Drive, Chain Brake, Chain Tensioner	7	7.3	Flywheel	42	11.3	Servicing the Carburetor	67
4.2	Rewind Starter	8	7.4	Contact Spring	43	11.3.1	Metering Diaphragm	67
4.3	Chain Lubrication	9	7.5	Replacing Wiring Harness	43	11.3.2	Inlet Needle	68
4.4	Ignition System	10	7.6	Ignition System Troubleshooting	45	11.3.3	Fixed Jet	69
4.5	Carburetor	11				11.3.4	Pump Diaphragm	69
4.6	Engine	13	8.	Rewind Starter	48	11.4	Adjusting Carburetor	71
			8.1	General	48	11.4.1	User Adjustment (Carburetor without Limiter Caps)	71
5.	Clutch, Chain Drive, Chain Brake and Chain Tensioner	14	8.2	Removing and Installing	48	11.4.2	User Adjustment (Carburetor with Limiter Caps)	72
5.1	Clutch Drum/Chain Sprocket	14	8.3	Pawl	48	11.4.3	Basic Setting (Carburetor with Limiter Caps)	73
5.2	Chain Catcher	15	8.4	Rope Rotor	49	11.5	Tank Vent	74
5.3	Spiked Bumper	15	8.5	Starter Rope/Grip	49	11.5.1	Machines up to 2002	74
5.4	Collar Stud	16	8.5.1	Tensioning	51	11.5.2	Machines from 2002	75
5.5	Clutch	16	8.6	Starter Rope Guide Bushing	52	11.6	Fuel Tank	76
5.6	Chain Brake	18	8.7	Replacing Rewind Spring	52	11.6.1	Pickup Body	76
5.6.1	Checking Operation	18				11.6.2	Suction Hose	76
5.6.2	Removing and Installing	18	9.	AV Handle System/ Handle Housing	53	11.6.3	Tank Cap	77
5.7	Replacing Pins	21	9.1	Front Handle	53	11.6.4	Replacing Engine Housing	77
5.7.1	Removing	21	9.2	Handle Housing	54			
5.7.2	Installing	22	9.3	Annular Buffers	56	12.	Special Servicing Tools	79
5.8	Chain Tensioner	23	9.3.1	Front Handle/ Handle Housing	56			
6.	Engine	23	9.3.2	Handle Housing/ Engine Housing	56	13.	Servicing Aids	81
6.1	Muffler/Spark Arresting Screen	23	9.3.3	Front Handle/Engine Housing	57			
6.2	Leakage Test	25	9.4	Switch Shaft	58			
6.2.1	Preparations	25	9.5	Throttle Trigger/ Interlock Lever	59			
6.2.2	Pressure Test	26						
6.2.3	Vacuum Test	26						
6.3	Oil Seals	27						
6.4	Shroud	29						

STIHL[®]

© ANDREAS STIHL AG & Co. KG, 2004

1. Introduction

This service manual contains detailed descriptions of all the typical repair and servicing procedures for this power tool.

As the design concept of models MS 290, MS 310 and MS 390 is almost identical, the descriptions and servicing procedures in this manual generally apply to all three models. Differences are described in detail.

You should make use of the illustrated parts lists while carrying out repair work. They show the installed positions of the individual components and assemblies.

Refer to the latest edition of the relevant parts list to check the part numbers of any replacement parts.

A fault on the machine may have several causes. To help locate the fault, consult the chapter on "Troubleshooting" and the "STIHL Service Training System".

Refer to the "Technical Information" bulletins for engineering changes which have been introduced since publication of this service manual. Technical information bulletins also supplement the parts list until an updated edition is issued.

The special tools mentioned in the descriptions are listed in chapter "Special Servicing Tools" of this manual. Use the part numbers to identify the tools in the "STIHL Special Tools" manual which lists all the special servicing tools currently available from STIHL.

Symbols are included in the text and pictures for greater clarity. The meanings are as follows:

In the descriptions:

- = Action to be taken as shown in the illustration (above the text)
- = Action to be taken that is not shown in the illustration (above the text)

In the illustrations:

- Pointer (short arrow)
- ➡ Direction of movement (long arrow)
- 📖 4.2 = Reference to another chapter, i.e. chapter 4.2 in this example.

Service manuals and technical information bulletins are intended exclusively for the use of properly equipped repair shops. They must not be passed to third parties.

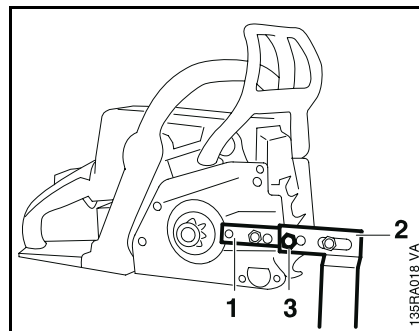

Servicing and repairs are made considerably easier if the clamp (1) 5910 890 2000 is used to mount the machine on assembly stand (2) 5910 890 3100 so that one clamp screw engages the outer 10 mm hole (3) in the assembly stand.

To service the underside of the machine, turn it upside down and mount it so that one clamp screw engages the inner 10 mm hole in the assembly stand.

Note:

Pull the hand guard back against the front handle for this purpose.

Always use original STIHL replacement parts.

They can be identified by the STIHL part number, the **STIHL** logo and the STIHL parts symbol . This symbol may appear alone on small parts.

2. Safety Precautions

If the engine is started up in the course of repairs or maintenance work, observe all local and country-specific safety regulations as well as the safety precautions and warnings in the instruction manual.

Gasoline is an extremely flammable fuel and can be explosive in certain conditions.

Improper handling may result in burns or other serious injuries.

Warning!

Do not bring any fire, flame, spark or other source of heat near the fuel. All work with fuel must be performed outdoors only. Spilled fuel must be wiped away immediately.

3. Specifications

3.1 Engine

	MS 290	MS 310	MS 390
Displacement:	56.5 cm ³	59.0 cm ³	64.1 cm ³
Bore:	46 mm	47 mm	49 mm
Stroke:	34 mm	34 mm	34 mm
Engine power to ISO 7293:	3.0 kW (4.1 bhp) at 9,500 rpm	3.2 kW (4.4 bhp) at 9,500 rpm	3.4 kW (4.6 bhp) at 9,500 rpm
Max. permissible engine speed with bar and chain:	12,500 rpm	13,000 rpm	13,000 rpm
Idle speed:	2,800 rpm		
Clutch:	Centrifugal clutch without linings		
Clutch engages at:	3,500 rpm		
Crankcase leakage test at gauge pressure:	0.5 bar		
under vacuum:	0.5 bar		

3.1.1 Engine (USA only)

	MS 290	MS 310	MS 390
Displacement:	3.44 cu. in	3.6 cu. in	3.91 cu. in
Bore:	1.81 in	1.85 in	1.92 in
Stroke:	1.33 in	1.33 in	1.33 in
Engine power to ISO 7293:	2.8 kW (3.8 bhp) at 9,500 rpm	3.0 kW (4.1 bhp) at 9,500 rpm	3.2 kW (4.4 bhp) at 9,500 rpm
Max. permissible engine speed with bar and chain:	12,500 rpm	13,000 rpm	13,000 rpm
Idle speed:	2,800 rpm		
Clutch:	Centrifugal clutch without linings		
Clutch engages at:	3,500 rpm		
Engine leakage test at gauge pressure:	7.25 psi		
under vacuum:	7.25 psi		

3.2 Fuel System

Carburetor leakage test at gauge pressure:	0.8 bar (11.60 psi)
Operation of tank vent at gauge pressure:	0.3 bar (4.35 psi)
Fuel:	as specified in instruction manual

3.3 Ignition System

Air gap between ignition module and fanwheel:	0.15 – 0.3 mm
Spark plug (suppressed):	Bosch WSR 6F NGK BPMP 7 A
Electrode gap:	0.5 mm

3.4 Chain Lubrication

Fully automatic, speed-controlled oil pump with rotary piston	
Oil delivery rate:	8 – 18 cm ³ at 10,000 rpm

3.5 Tightening Torques

DG screws are used in polymer and light metal components. These screws form a permanent thread when they are installed for the first time. They can be removed and installed as often as necessary without impairing the strength of the screwed assembly, providing the specified tightening torque is observed.

For this reason it is **essential to use a torque wrench**.

Fastener	Thread size	For component	Torque		Remarks
			kpm	Nm	
Screw	DG4x15	Cover, chain tensioner/engine housing	0.25	2.5	
Collar screw	DG8x24	Guide bar	1.6	16.0	
Collar screw	M10x21	Collar screw for guide bar/engine pan	3.0	30.0	1)
Screw	DG4x15	Chain brake cover/engine housing	0.25	2.5	
Screw	DG4x15	Handle housing/handle molding	0.16	1.6	
Screw	DG5x24	Handlebar/handle housing	0.35	3.5	
Screw	DG5x24	Hand guard, left	0.35	3.5	2)
Screw	DG4x15	Shroud/engine housing	0.25	2.5	
Slotted screw	M5	Box filter/carburetor	0.2	2.0	
Screw	DG5x16	Chain catcher/engine housing	0.35	3.5	
Screw	DG5x16	Spiked bumper/engine housing	0.35	3.5	
Screw	DG5x24	Fan housing/engine housing	0.35	3.5	
Screw	DG4x15	Ground connection to cylinder	0.4	4.0	
Carrier	M12x1L	Carrier/crankshaft	5.0	50.0	
Screw	DG6x52	Engine housing/cylinder	1.1	11.0	
Screw	DG5x24	Annular buffer/handlebar	0.35	3.5	
Screw	DG5x24	Annular buffer/engine housing	0.35	3.5	
Locknut	M5	Muffler cover/cylinder/screw	0.8	8.0	
Nut	M8x1	Flywheel/crankshaft	2.8	28.0	
Nut	M5	Carburetor/handle housing/screw	0.33	3.3	
Spark plug	M14x1.25	Spark plug	2.5	25.0	
Screw	DG5x24	Ignition module/engine housing	0.48	4.8	
Screw	DG4x15	Oil pump	0.4	4.0	

Remarks:

1) Loctite 243, medium strength

2) with sleeve

4. Troubleshooting Chart
4.1 Clutch, Chain Drive, Chain Brake, Chain Tensioner

Condition	Cause	Remedy
Saw chain stops under load at full throttle	Clutch shoes badly worn	Install new clutch
	Clutch drum badly worn	Install new clutch drum
	Brake band stuck	Check freedom of movement and function of brake band
Saw chain rotates at idle speed	Engine idle speed too high	Readjust with idle speed screw (LA) (counterclockwise)
	Clutch springs stretched or fatigued	Replace the clutch springs, or clutch if necessary
	Clutch spring hooks broken	Replace the clutch springs
Loud noises	Clutch springs stretched or fatigued	Replace all clutch springs
	Needle cage damaged	Fit new needle cage
	Clutch shoe retainer broken	Fit new retainer
	Clutch shoes and carrier worn	Install new clutch
Chain sprocket wears rapidly	Chain not properly tensioned	Tension chain as specified
	Wrong chain pitch	Fit chain of correct pitch
	Insufficient chain lubrication	Check chain lubrication
	Chain sprocket worn	Install new chain sprocket
Chain does not stop immediately when brake is activated	Brake spring stretched or broken	Fit new brake spring
	Brake band stretched / worn / broken	Fit new brake band
	Clutch drum worn	Install new clutch drum

4.2 Rewind Starter

Condition	Cause	Remedy
Starter rope broken	Rope pulled out too vigorously as far as stop or over edge, i.e. not vertically	Fit new starter rope
	Normal wear	Fit new starter rope
Starter rope does not rewind	Rewind spring broken	Fit new rewind spring
	Spring overtensioned – no reserve when rope is fully extended	Fit new rewind spring
	Very dirty or corroded	Clean or replace rewind spring
Starter rope can be pulled out almost without resistance (crankshaft does not turn)	Guide peg on pawls or pawls themselves are worn	Fit new pawls
	Spring clip fatigued	Fit new spring clip
Starter rope is difficult to pull and rewinds very slowly	Starter mechanism is very dirty	Clean complete starter mechanism
	Lubricating oil on rewind spring becomes viscous at very low outside temperatures (spring windings stick together)	Coat rewind spring with a standard solvent-based degreasant (containing no chlorinated or halogenated hydrocarbons). Then pull rope carefully several times until normal action is restored

4.3 Chain Lubrication

In the event of trouble with the chain lubrication system, check and rectify other sources of faults before disassembling the oil pump.

Condition	Cause	Remedy
Chain receives no oil	Oil tank empty	Fill up with oil
	Oil inlet hole in guide bar is blocked	Clean oil inlet hole
	Intake hose or pickup body (strainer) clogged or intake hose ruptured	Replace suction hose and pickup body
	Sealing ring between oil pump and elbow connector or between elbow connector and engine housing faulty	Remove oil pump, fit new sealing ring and refit oil pump
	Valve in oil tank blocked	Clean/replace valve
	Teeth on pump piston and/or worm worn	Fit new oil pump
Machine losing chain oil	Sealing ring between oil pump and elbow connector or between elbow connector and engine housing faulty	Remove oil pump, fit new sealing ring and refit oil pump
	Oil pump damaged or worn	Fit new oil pump
Oil pump delivers insufficient oil	Control screw and/or control edge on pump piston worn	Replace control screw and/or oil pump
	Oil pump worn	Fit new oil pump

4.4 Ignition System

Warning!

Exercise extreme caution while carrying out maintenance and repair work on the ignition system. The high voltages which occur can cause serious or fatal accidents!

Condition	Cause	Remedy
Engine runs roughly, misfires, temporary loss of power	Spark plug boot is loose	Press boot firmly onto spark plug and fit new spring if necessary
	Spark plug sooted, smeared with oil	Clean the spark plug or replace if necessary
	Incorrect air gap between ignition coil and flywheel	Set air gap correctly
	Flywheel cracked or has other damage or pole shoes have turned blue	Install new flywheel
	Ignition timing wrong, flywheel out of adjustment, key in flywheel has sheared off	Install new flywheel
	Weak magnetization in flywheel – pole shoes have turned blue	Install new flywheel
	No ignition spark	Check operation of Master Control lever and ignition module
No ignition spark		Faulty insulation on ignition lead or short circuit wire. Use ohmmeter to check ignition lead for break. If break is detected or high resistance measured, fit a new ignition lead
	Check operation of spark plug. Inspect Master Control lever, ignition coil/lead for damage insulation and leakage current.	Clean or replace spark plug, replace faulty parts of ignition system
	Engine pan damaged (cracks)	Replace engine pan

4.5 Carburetor

Condition	Cause	Remedy
Carburetor floods; engine stalls	Inlet needle not sealing. Foreign matter in valve seat or cone damaged	Remove and clean or replace the inlet needle, clean the fuel tank, pickup body and fuel line if necessary
	Inlet control lever sticking on spindle	Free off inlet control lever
	Helical spring not located on nipple of inlet control lever	Remove the inlet control lever and refit it correctly
	Perforated disc on diaphragm is deformed and presses constantly against the inlet control lever	Fit a new metering diaphragm
	Inlet control lever too high (relative to correct installed position)	Set inlet control lever flush with top edge of housing
Poor acceleration	Idle jet too lean	Rotate low speed screw (L) counterclockwise (richer), no further than stop
	Main jet too lean	Rotate high speed screw (H) counterclockwise (richer), no further than stop
	Inlet control lever too low (relative to correct installed position)	Set inlet control lever flush with top edge of housing
	Inlet needle sticking to valve seat	Remove inlet needle, clean and refit
	Diaphragm gasket leaking	Fit new diaphragm gasket
	Metering diaphragm damaged or shrunk	Fit new metering diaphragm
	Impulse hose damaged or kinked	Fit new impulse hose

Condition	Cause	Remedy
Engine will not idle, idle speed too high	Throttle shutter opened too wide by idle speed screw (LA)	Reset idle speed screw (LA) correctly
	Engine leaking	Seal the engine
Engine stalls at idle speed	Idle jet bores or ports blocked	Clean jet bores and ports and blow clear with compressed air
	Idle jet too rich or too lean	Set low speed screw (L) correctly
	Setting of idle speed (LA) incorrect – throttle shutter completely closed	Set idle speed screw (LA) correctly
	Small plastic plate in valve jet does not close	Clean or renew valve jet
Engine speed drops quickly under load – low power	Air filter dirty	Clean the air filter
	Throttle shutter not opened fully	Check linkage
	Tank vent faulty	Clean tank vent or replace if necessary
	Fuel pickup body dirty	Clean the pickup body, fit a new filter
	Fuel strainers dirty	Replace the fuel strainers
	Leak in fuel line between tank and fuel pump	Seal connections or install a new fuel line
	Setting of high speed screw (H) too rich	Rotate high speed screw (H) clockwise (leaner), no further than stop
	Main jet bores or ports blocked	Clean the carburetor
Pump diaphragm damaged or fatigued	Fit new pump diaphragm	

4.6 Engine

Always check and, if necessary, repair the following parts before looking for faults on the engine:

- Air filter
- Fuel system
- Carburetor
- Ignition system

Condition	Cause	Remedy
Engine does not start easily, stalls at idle speed, but operates normally at full throttle	Manifold leaking	Seal or replace the manifold
	Oil seals on crankshaft damaged	Replace the oil seals
	Joint between cylinder and engine pan leaking or damaged (cracks)	Seal or replace engine pan
Engine does not deliver full power or runs erratically	Piston rings worn or broken	Fit new piston rings
	Muffler / spark arresting screen (if fitted) carbonized	Clean the muffler (inlet and exhaust), replace spark arresting screen, replace muffler if necessary
	Air filter element dirty	Replace air filter element
	Fuel / impulse line severely kinked or damaged	Replace lines or position them free from kinks
Engine overheating	Insufficient cylinder cooling. Air inlets in fan housing blocked or cooling fins on cylinder very dirty	Thoroughly clean all cooling air openings and the cylinder fins

5. Clutch, Chain Drive, Chain Brake and Chain Tensioner

5.1 Clutch Drum/Chain Sprocket

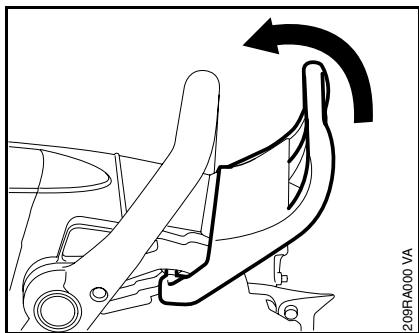

– Remove the chain sprocket cover.

- Disengage the chain brake by pulling the hand guard towards the front handle.

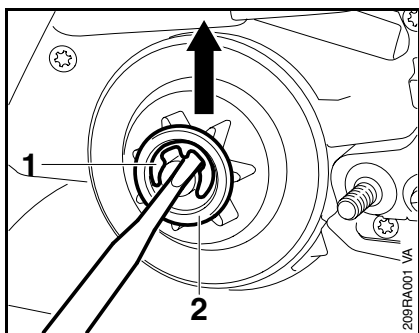

- Remove the E-clip (1).
- Remove the washer (2).

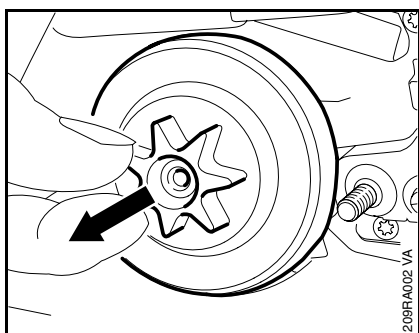

- If a rim sprocket is fitted, pull it off.
- Remove the clutch drum/chain sprocket.

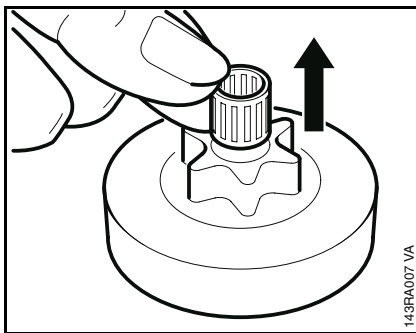

- Remove the needle cage.
- Clean the clutch drum/chain sprocket with standard solvent-based degreasant containing no chlorinated or halogenated hydrocarbons, 13.

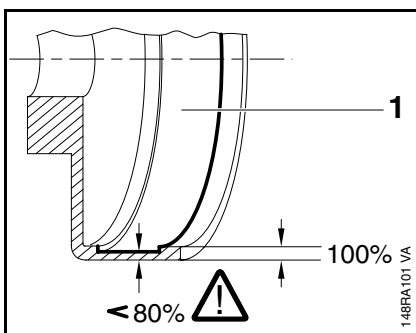

- Inspect the clutch drum (1) for signs of wear.

If there are signs of serious wear on the inside diameter of the clutch drum (1), check the remaining wall thickness. If it is less than about 80% of the original thickness, fit a new clutch drum.

If the clutch drum has to be replaced, also check the brake band, 5.6.2

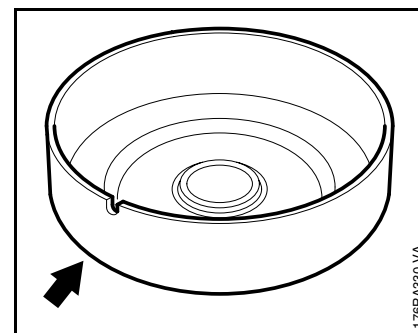

- If the clutch drum/chain sprocket is still serviceable, use No. 120 emery paper or emery cloth (grain size approx. 120 μm) to clean and roughen its friction surface.

Install in the reverse sequence.

- Clean crankshaft stub with standard solvent-based degreasant containing no chlorinated or halogenated hydrocarbons. Wash needle cage and lubricate with grease, 13.
- Replace damaged needle cage.

5.2 Chain Catcher

- Rotate clutch drum/chain sprocket and apply slight pressure at the same time until the oil pump drive spring engages the notch.
- Fit rim sprocket with the cavities facing outwards.

Install all other parts in the reverse sequence.

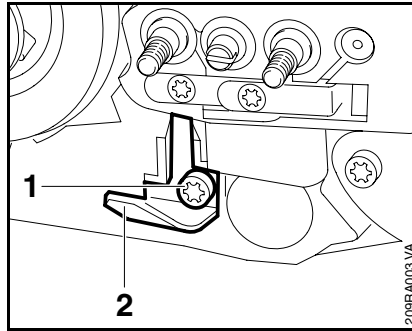

- Remove the chain sprocket cover, bar and chain.
- Take out the screw (1).
- Remove the chain catcher (2).

Install in the reverse sequence.

Check correct installed position.

5.3 Spiked Bumper

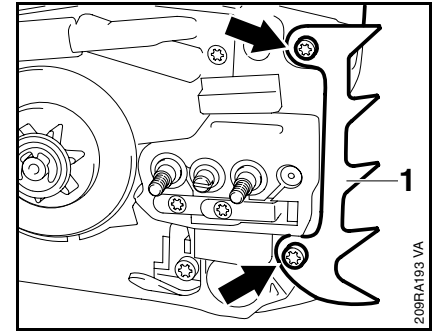

- Remove the chain sprocket cover, bar and chain.
- Take out the screws (arrows).
- Remove the spiked bumper (1).

Install in the reverse sequence.

5.4 Collar Stud

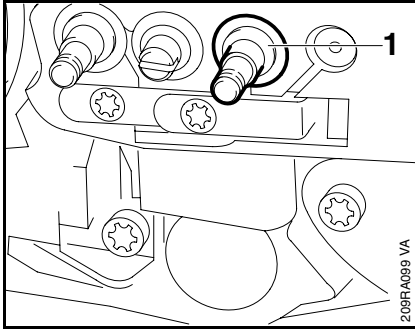

– Remove the chain sprocket cover with cutting attachment.

- Use M 8 stud puller 5910 893 0501,  12, to remove the collar stud (1).

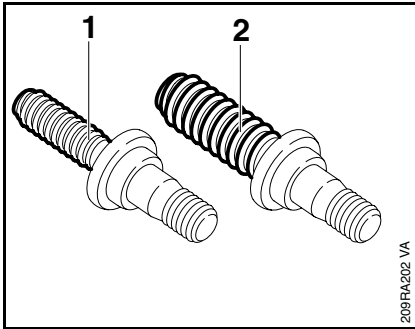



If the thread in the engine housing is badly damaged or stripped, it will not be possible to secure the standard collar stud (1) properly. This situation can be remedied by using the DG 9 collar stud 1127 664 2410 (2).

Do not drill out the mounting bore in the engine housing.

- Coat thread of the DG 9 collar stud with Loctite 648,  13.
- Install the collar stud squarely.

5.5 Clutch

- Troubleshooting –  4.1
- Remove the clutch drum/chain sprocket,  5.1
- Remove the prefilter,  11.1

Install all other parts in the reverse sequence.

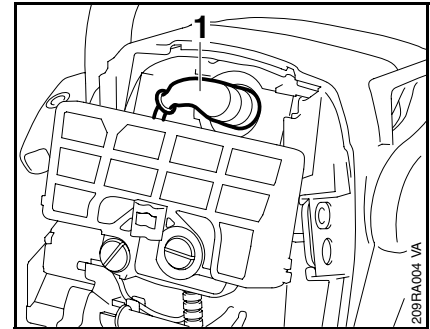

- remove the spark plug boot (1).
- Unscrew the spark plug.

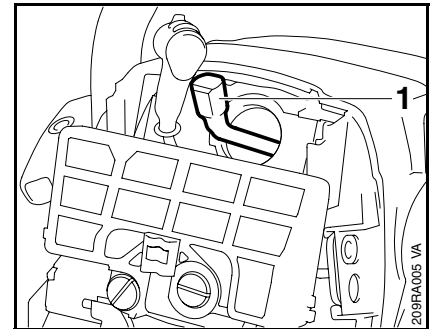

- Push the locking strip (1) 0000 893 5903 into the spark plug hole so that "TOP" faces up.

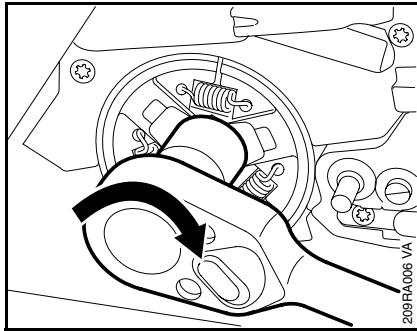

- Unscrew the clutch from the crankshaft in the direction of the arrow (left-hand thread).

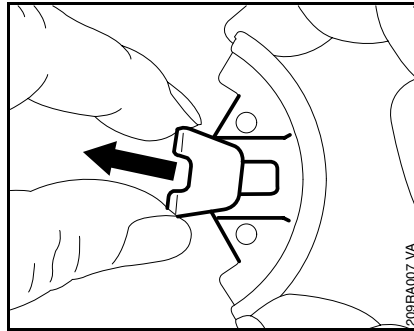

- Pull the retainers off the clutch shoes.

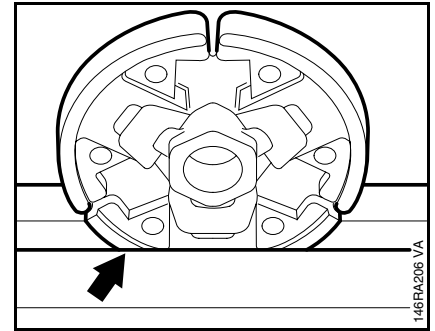

- Carefully clamp the clutch in a vise.

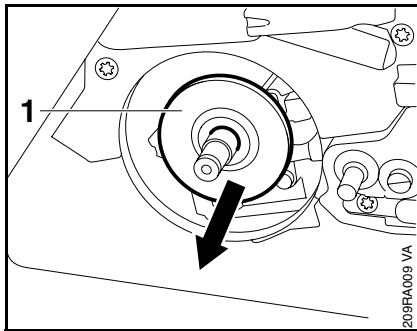

- Take the cover washer (1) (where fitted) off the crankshaft.

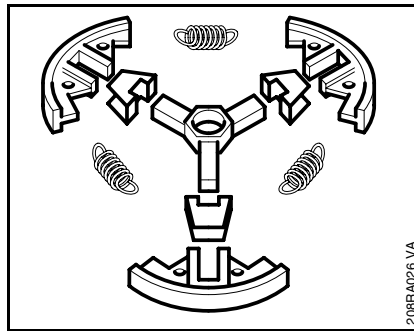

- Clean all parts in a little standard solvent-based degreasant containing no chlorinated or halogenated hydrocarbons, 13.
- Replace any damaged parts.

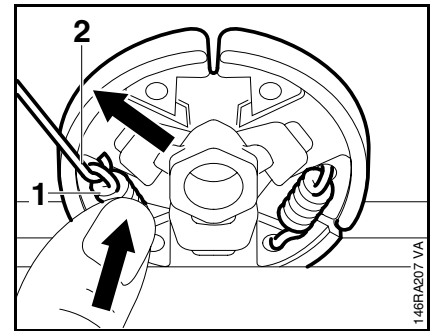

- Attach one end of each spring (1) to the clutch shoes.
- Use the hook (2) 5910 890 2800 to attach other ends of springs and press them firmly into the clutch shoes.

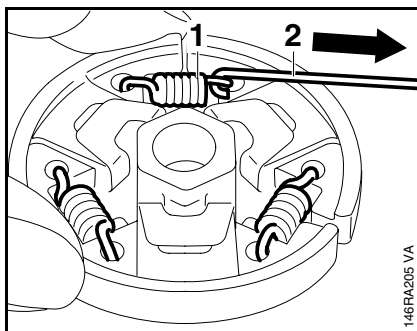

- Use hook (2) 5910 890 2800 to remove the clutch springs (1).
- Pull the clutch shoes off the carrier.

Install in the reverse sequence.

Important:

Clutches marked **1125/01** on the carrier must be installed **without** cover washer.

Clutches marked **1127/00** on the carrier must be installed **with** cover washer.

5.6 Chain Brake

5.6.1 Checking Operation

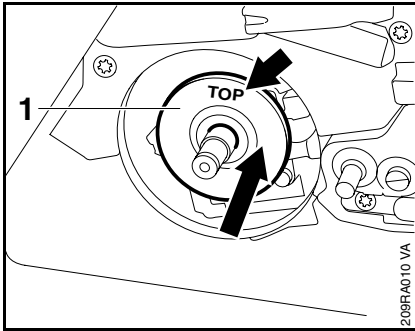

- Push cover washer (1), "TOP" (arrow) facing outward, onto the crankshaft.

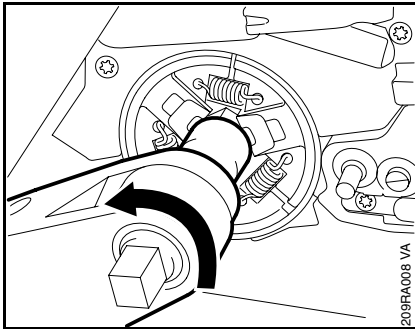

- Screw on the clutch and tighten it down firmly, 3.5

Install all other parts in the reverse sequence.

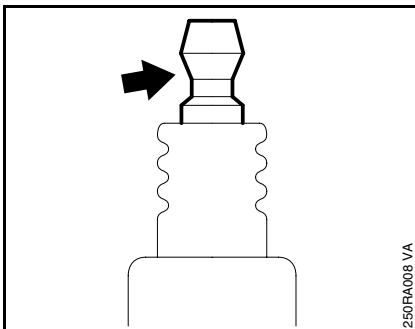

- If terminal of spark plug has a detachable adapter nut, make sure it is tightened down firmly.

The chain brake is one of the most important safety devices on the chainsaw. Its efficiency is measured in terms of the chain braking time, i.e. the time that elapses between activating the brake and the saw chain coming to a complete standstill. The shorter the braking time, the better the efficiency and protection offered against being injured by the rotating chain.

Contamination (with chain oil, chips, fine particles of abrasion, etc.) and smoothing of the friction surfaces of the brake band and clutch drum impair the coefficient of friction. This, in turn, reduces the frictional forces and thus prolongs the braking time. A fatigued or stretched brake spring has the same negative effect.

- Start the engine.
- With the chain brake activated (locked), open the throttle wide for a brief period (max. 3 seconds) – the chain must not rotate.
- With the chain brake released, open the throttle wide and activate the brake manually – the chain must come to an abrupt stop.

The braking time is in order if deceleration of the saw chain is imperceptible to the eye.

5.6.2 Removing and Installing

- Remove the clutch drum/chain sprocket, 5.1
- Relieve tension of brake spring by pushing hand guard forward.

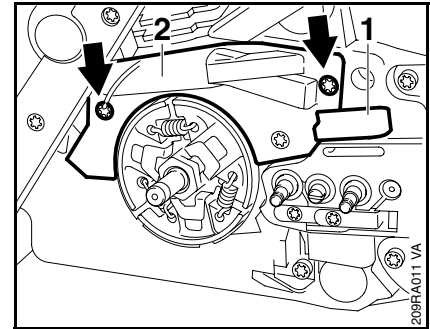

- Remove the bumper strip (1).
- Take out the screws (arrows).
- Remove the cover (2).

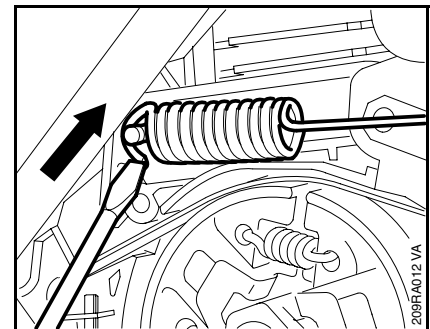

- Carefully ease the brake spring off the anchor pin.
- If the groove in the anchor pin is worn, install a new pin, 5.7.1

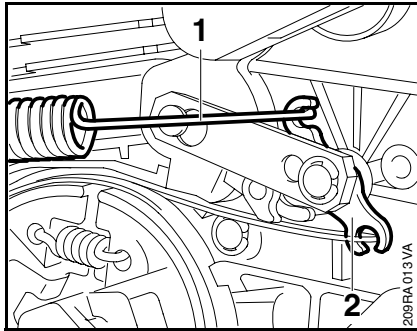

- Remove the brake spring (1) from the bell crank (2).

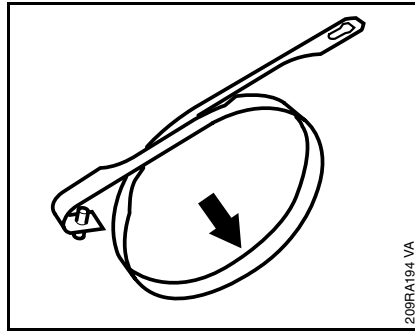

- Install a new brake band if there are noticeable signs of wear (large areas on inside diameter and/or parts of outside diameter) and its remaining thickness is less than 0.6 mm.

Thickness of brake band must not be less at any point.

- If the brake band is still serviceable, use No. 120 emery paper or emery cloth (grain size approx. 120 µm) to clean and roughen its friction surface (inside diameter).

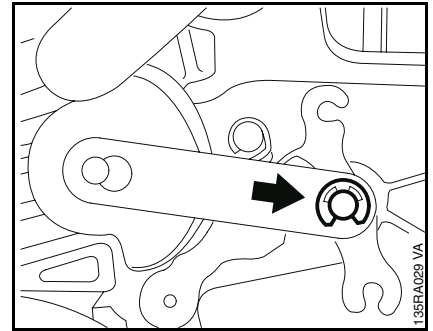

- Remove the E-clip (arrow).

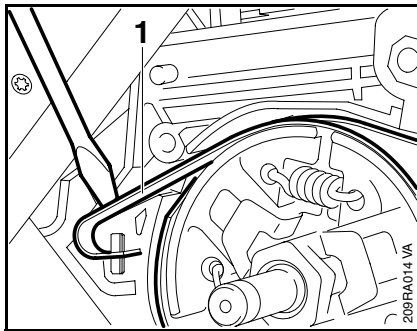

- Pry the brake band (1) out of the engine housing.

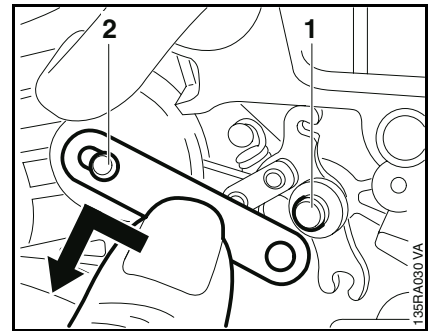

- Remove the strap from the bell crank pivot pin (1).
- Slide the strap up and take it off the hand guard pivot pin (2).

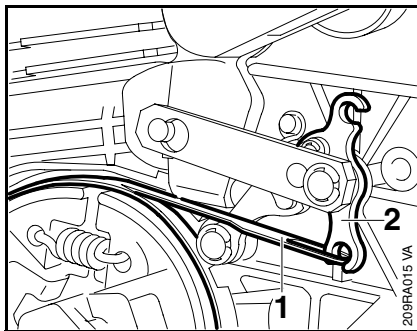

- Disconnect the brake band (1) from the bell crank (2).

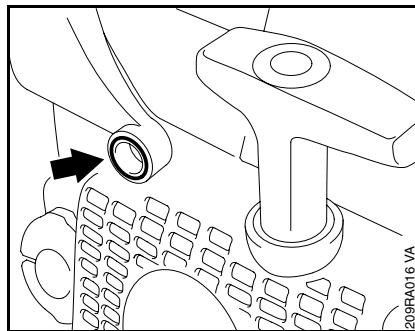

- Take the screw (1) together with the bushing (2) out of the hand guard.

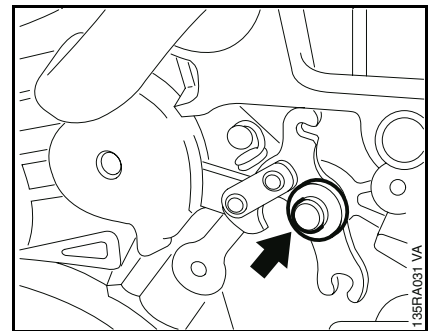

- Remove the washer (arrow).

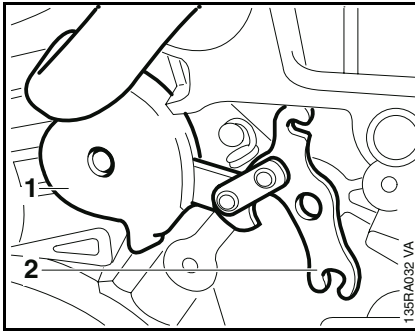

- Carefully pry the hand guard (1) and bell crank (2) off their pivot pins and remove them together.
- Pull the bell crank out of the hand guard.

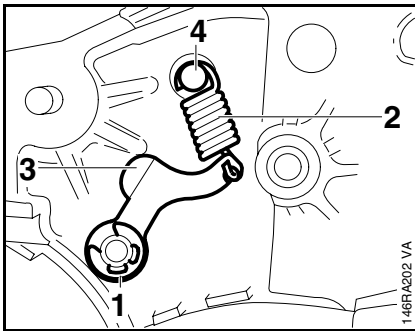

- Detach the spring (2).
- Remove the E-clip (1).
- Pull off the cam lever (3).
- Inspect parts and replace if damaged.
- Clean the entire housing recess for the chain brake.
- If the groove in the pin (4) (for spring) is worn, install a new pin, 5.7.1
- If necessary, pull the bell crank out of the hand guard.

Install in the reverse sequence.

- Lubricate all sliding and bearing points with STIHL multipurpose grease or, preferably, molybdenum grease (e.g. Molykote), 13.

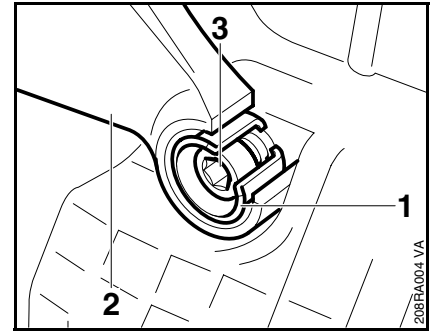

- Fit the bushing (1) in the hand guard (2).
- Insert M5x24 screw (3) and tighten it down firmly, 3.5

Install all other parts in the reverse sequence.

- Check operation of chain brake, 5.6.1

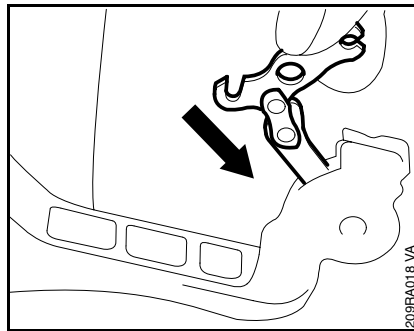

- Push the bell crank into the side of the hand guard. The short arm of the bell crank must point to the top of the hand guard.

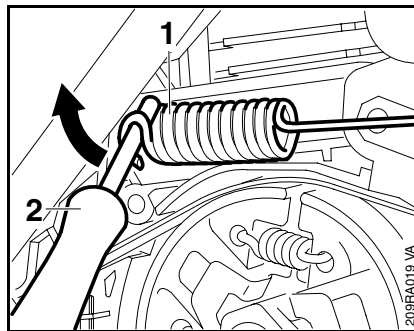

- Use assembly tool (2) 1117 890 0900 to attach the brake spring (1) to the anchor pin.

5.7 Replacing Pins

5.7.1 Removing

If the groove of the anchor pin is worn, install a new pin.

Drive out the pin in the direction of the arrow so as not to damage the annular bead which was formed in the engine housing bore when the pin was originally installed. The new anchor pin will not otherwise fit properly and the brake spring will not be held securely.

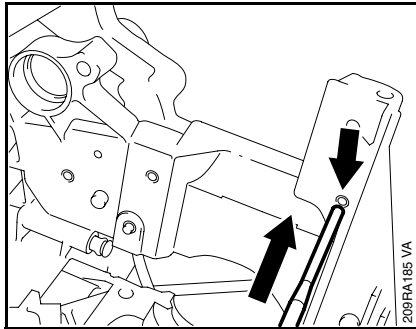

Brake spring anchor pin

- Disconnect the brake spring, 5.6.2
- Remove the cylinder, 6.5.1
- Use a 4 mm drift to remove the pin by driving it outwards.

If the pin cannot be seen on the inside of the housing, use a suitable tool to expose it.

- Installing, 5.7.2

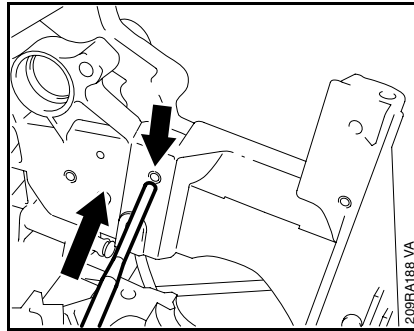

Hand guard pivot pin

- Remove the hand guard, 5.6.2
- Remove the cylinder, 6.5.1
- Use a 4 mm drift to remove the pin by driving it outwards.
- Installing, 5.7.2

Spring anchor pin

- Remove the muffler, 6.1
- Remove the handle housing, 9.2

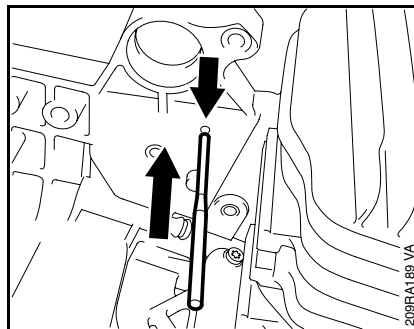

- Use a 2 mm drift to remove the pin by driving it outwards.
- Installing, 5.7.2

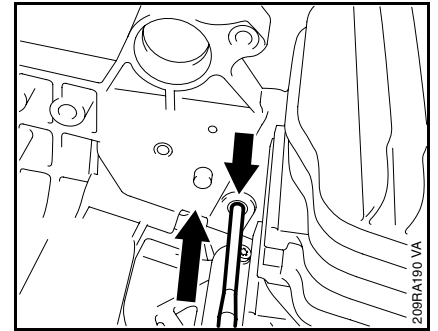

Cam lever pivot pin

- Remove the muffler, 6.1
- Remove the handle housing, 9.2
- Use a 4 mm drift to remove the pin by driving it outwards.
- Installing, 5.7.2

Lever pivot pin

- Remove the muffler, 6.1
- Remove the handle housing, 9.2

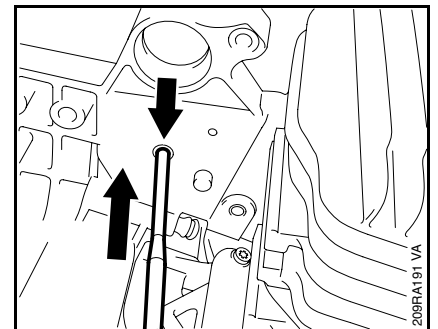

- Use a 4 mm drift to remove the pin by driving it outwards.
- Installing, 5.7.2

5.7.2 Installing

- Before installation, coat the knurled area of the new pin with Loctite 243,  13.
- Position the new pin in the bore so that the knurling on the pin meshes with the existing knurling in the bore. Turn pin back and forth as necessary.
- Carefully tap home the pin squarely from the outside inwards, in direction of cylinder.

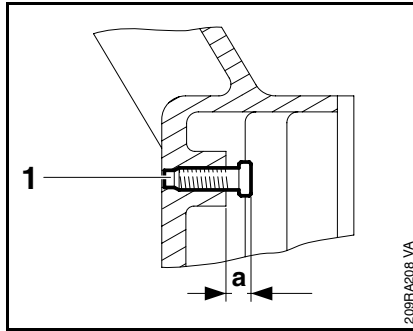

Spring anchor pin

- Drive home pin (1) until dimension “a” is 3.0 ± 0.2 mm

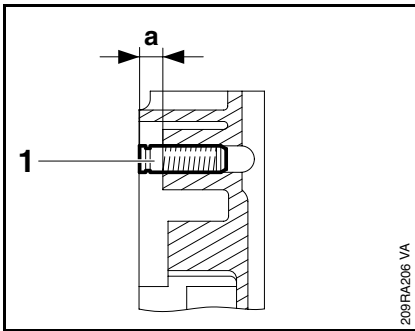

Brake spring anchor pin

- Drive home pin (1) until dimension “a” is 4.5 ± 0.2 mm

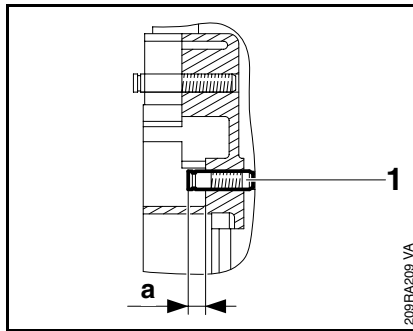

Cam lever pivot pin

- Drive home pin (1) until dimension “a” is 4.6 ± 0.2 mm

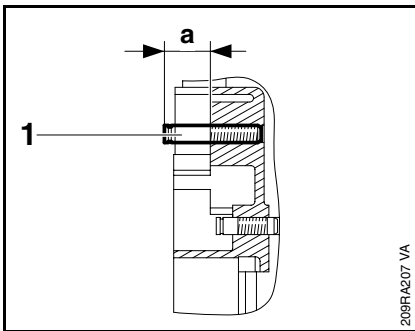

Hand guard pivot pin

- Drive home pin (1) until dimension “a” is 12 ± 0.2 mm

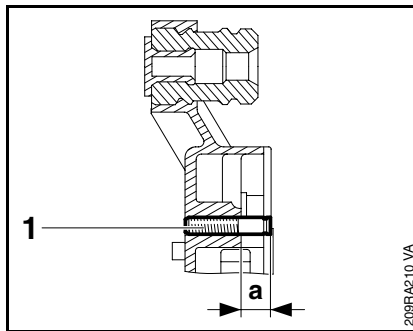

Lever pivot pin

- Drive home pin (1) until dimension “a” is 9.1 ± 0.2 mm

Install all other parts in the reverse sequence.

5.8 Chain Tensioner

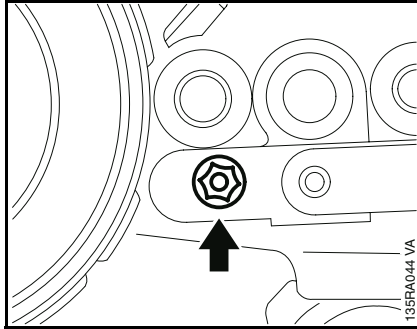

- Remove the chain sprocket cover.
- Take out the screw (arrow).
- Pull tensioner assembly out of the engine housing.

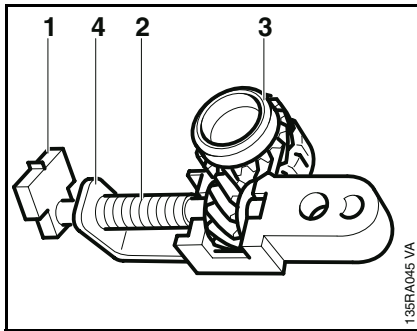

- Take the thrust pad (1) off the adjusting screw (2).
- Rotate the spur gear (3) until the adjusting screw comes out of the tensioner slide (4).

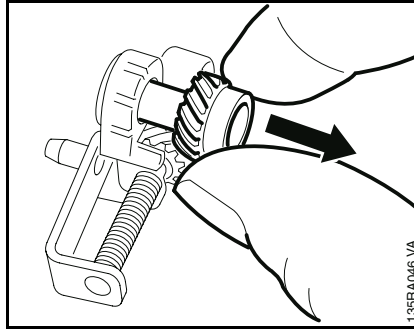

- Pull the spur gear out of the cover.

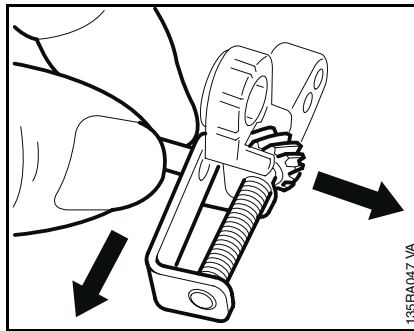

- Pull the tensioner slide off the cover.
- Take the adjusting screw out of the cover.
- Inspect the teeth on the spur gear and adjusting screw. Replace both parts if necessary.

Install in the reverse sequence.

- Coat teeth of adjusting screw and spur gear with grease, 13, before refitting.

6. Engine 6.1 Muffler/Spark Arresting Screen

This machine does not have a conventional crankcase. The engine consists of the cylinder, piston, crankshaft and engine pan.

- Troubleshooting, 4.6

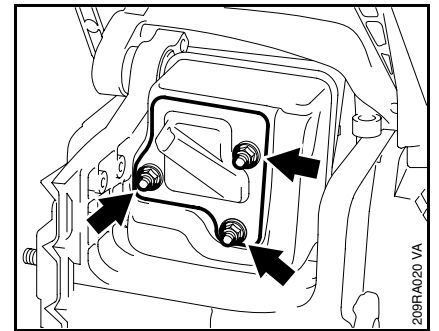

- Unscrew the nuts (arrows).

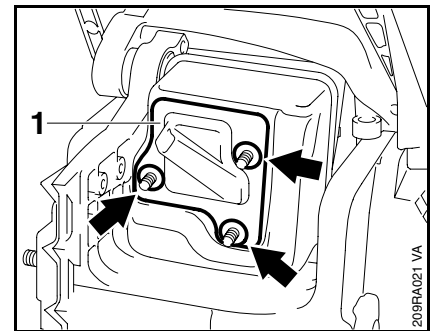

- Remove the conical spring washers (arrows).
- Remove the cover (1).

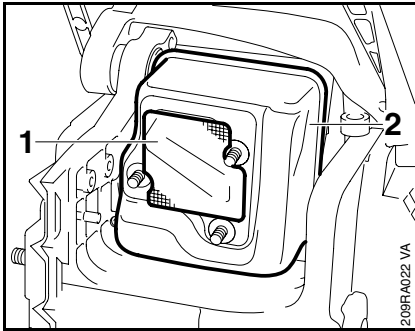

- Remove spark arresting screen (1), if fitted. Clean the screen or fit a new one if necessary
- Remove the muffler (2).

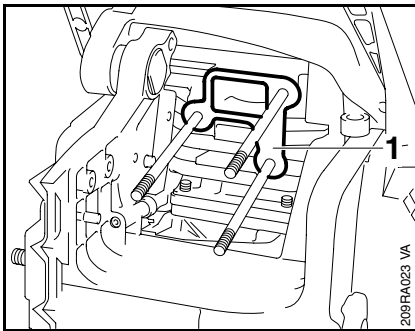

- Remove the gasket (1).

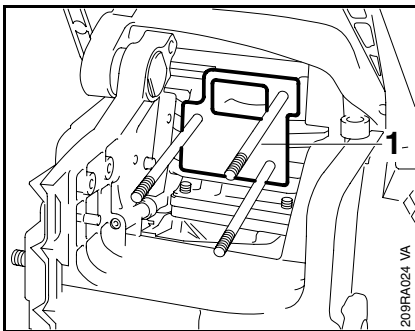

MS 390 (US version only)

- Remove the exhaust gasket (1).

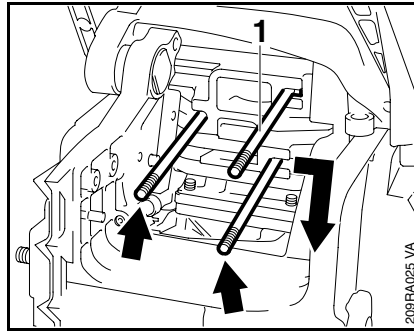

- Remove the screws (arrows) sideways from the flange.

Remove screw (1) as follows:

- Remove the shroud, 6.4
- Remove the screw sideways from the flange.

Install in the reverse sequence.

Install new gaskets.

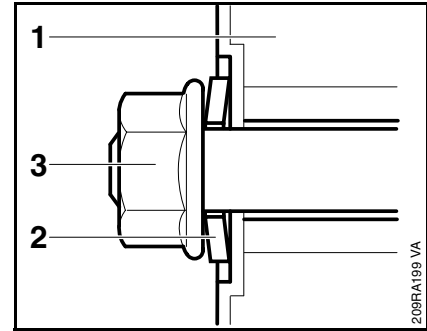

- Install the muffler (1), making sure the conical spring washers (2) are fitted correctly as shown.
- Use new nuts (3) and tighten them down firmly, 3.5.

6.2 Leakage Test

Defective oil seals and gaskets or cracks in castings are the usual causes of leaks. Such faults allow supplementary air to enter the engine and upset the fuel-air mixture.

This makes adjustment of the prescribed idle speed difficult, if not impossible.

Moreover, the transition from idle speed to part or full throttle is not smooth.

The engine housing can be checked thoroughly for leaks with the carburetor and crankcase tester and the vacuum pump,  11.2.2

6.2.1 Preparations

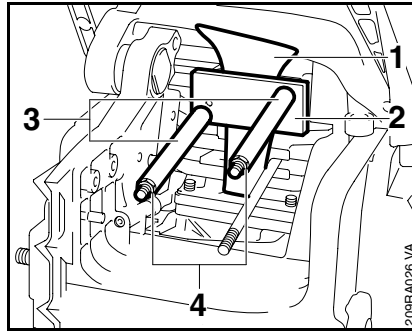

– Remove the muffler,  6.1

- Fit the sealing plate (1) 0000 855 8106 between the mounting screws.

The sealing plate must completely fill the space between the two mounting screws.

- Slip the flange (2) 1123 855 4200 over the screws.
- Fit the sleeves (3) 1123 851 8300 on the screws.
- Fit the nuts (4) and tighten down securely,  3.5

– Remove the carburetor,  11.2.1

– Set the piston to top dead center (T.D.C.). This can be checked through the inlet port.

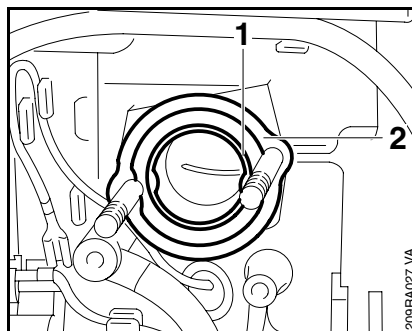

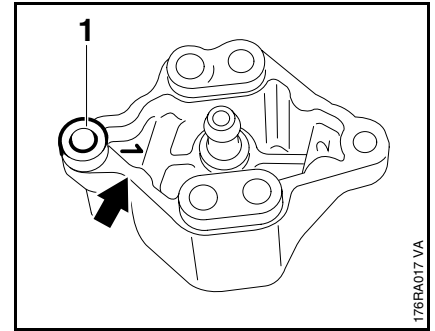

- Check that the sleeve (1) and washer (2) are properly seated.

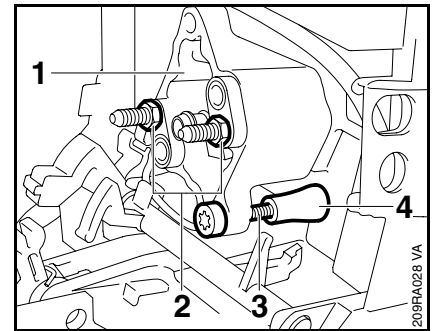

- Check that the pin (1) in test flange 1128 850 4200 is in hole No. 1 (arrow), or fit if necessary.



- Fit the test flange (1).
- Tighten down the screws (2) firmly,  3.5
- Check that spark plug is properly tightened down.
- Pressure test,  6.2.2
- Vacuum test,  6.2.3

When fitting the test flange, make sure the pin (3) locates properly in the impulse hose (4).

6.2.2 Pressure Test

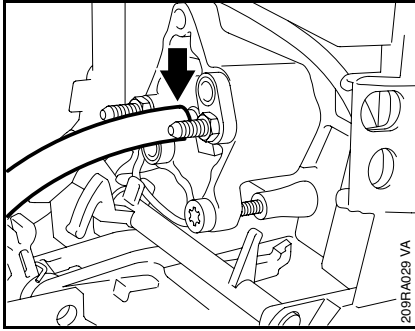

- Carry out preparations, 6.2.1
- Connect pressure hose to nipple (arrow) on test flange.

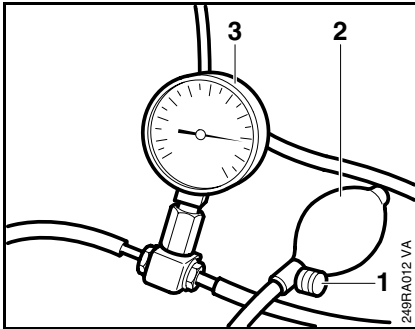

- Close vent screw (1) on the rubber bulb.
- Pump air into the crankcase with rubber bulb (2) until the gauge (3) indicates a pressure of 0.5 bar.

If this pressure remains constant for at least 20 seconds, the crankcase is airtight.

If the pressure drops, the leak must be found and the faulty part replaced.

To find the leak, coat the suspect area with oil and pressurize the crankcase again. Bubbles will appear if a leak exists.

- Repeat the pressure test if necessary.
- After finishing the test, open the vent screw and disconnect the hose.

- Continue with vacuum test, 6.2.3

6.2.3 Vacuum Test

Oil seals tend to fail when subjected to a vacuum, i.e. the sealing lip lifts away from the crankshaft during the piston's induction stroke because there is no internal counterpressure.

A test can be carried out with the vacuum pump to detect this kind of fault.

- Carry out pressure test, 6.2.2

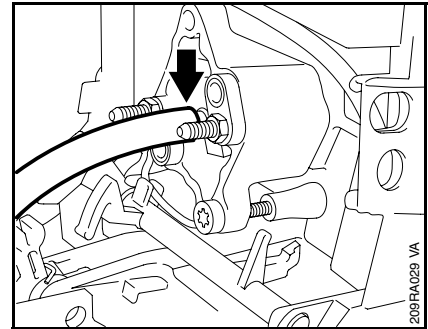

- Connect suction hose of vacuum pump 0000 850 3501 to nipple (arrow) of the test flange.

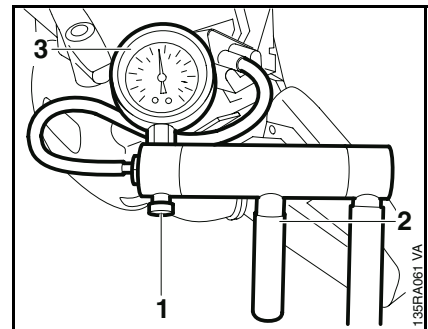

- Close the vent screw (1) on the pump.
- Operate lever (2) until pressure gauge (3) indicates a vacuum of 0.5 bar.

6.3 Oil Seals

If the vacuum reading remains constant, or rises to no more than 0.3 bar within 20 seconds, it can be assumed that the oil seals are in good condition.

However, if the pressure continues to rise (reduced vacuum in the crankcase), the oil seals must be replaced.

– After finishing the test, open the vent screw and disconnect the hose.

– Remove the test flange.

Install in the reverse sequence.

It is not necessary to disassemble the complete engine if only the oil seals have to be replaced.

Clutch side

– Remove the clutch,  5.5

– Remove the oil pump,  10.4.1

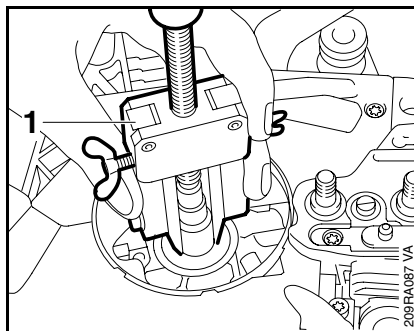

● Apply puller (1) 5910 890 4400 with No. 3.1 jaws 0000 893 3706.

– Clamp the puller arms.

– Pull out the oil seal.

Take care not to damage the crankshaft stub.

– Clean sealing face with standard solvent-based degreasant containing no chlorinated or halogenated hydrocarbons,  13.

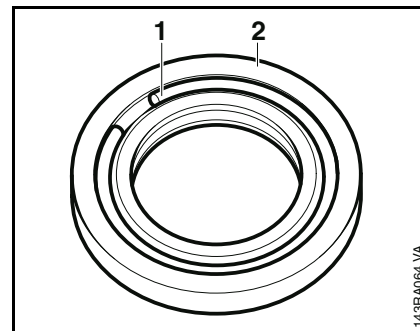

If the engine has **not** been disassembled, only the so-called “**soft**” oil seal 9639 010 1743 may be installed.

● Place the oil seal (2) in position with the clamping ring (1) facing up.

– Lubricate sealing lip of oil seal with grease,  13.

– Apply thin coating of sealant to the outside diameter of the oil seal,  13.

If the engine has been disassembled and the engine pan removed, it is recommended that the “**hard**” oil seal 9639 003 1743 be installed in place of the soft oil seal 9639 010 1743 **before** the engine pan is refitted.

Important:

Do not use a press to install the hard oil seal 9639 003 1743. Install **hard** oil seals as described in  6.7

Install in the reverse sequence.

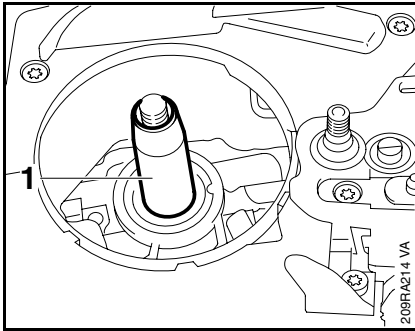

- Push the installing sleeve (1) 1122 893 4600 on to the crankshaft stub.

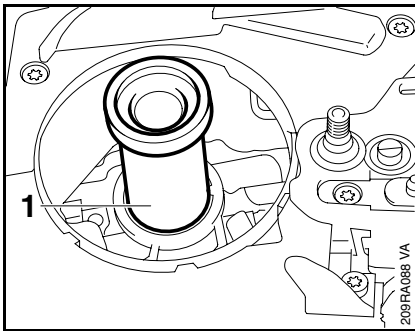

- Use press sleeve (1) 1127 893 2400 to install the "soft" oil seal.
- Wait about one minute, then rotate the crankshaft.
- Install the oil pump, 10.4.1

Install all other parts in the reverse sequence.

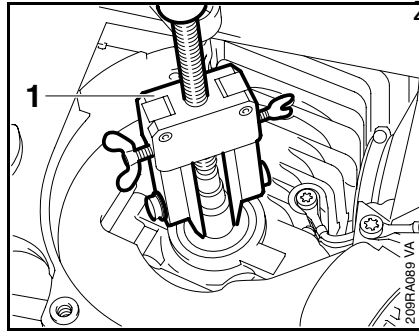

Ignition side

- Remove the flywheel, 7.3
- Apply puller (1) 5910 890 4400 with No. 3.1 jaws 0000 893 3706.
- Clamp the puller arms.
- Pull out the oil seal.

Take care not to damage the crankshaft stub.

- Clean sealing face with standard solvent-based degreasant containing no chlorinated or halogenated hydrocarbons, 13.

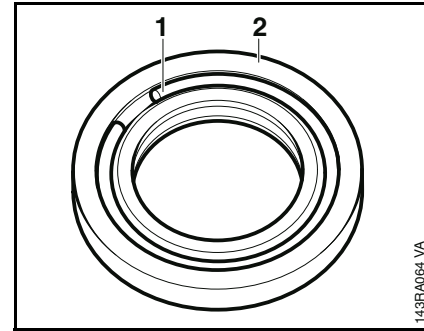

If the engine has **not** been disassembled, only the so-called "soft" oil seal 9639 010 1743 may be installed.

- Place the oil seal (2) in position with the clamping ring (1) facing up.
- Lubricate sealing lip of oil seal with grease, 13.
- Apply thin coating of sealant to the outside diameter of the oil seal, 13.

If the engine has been disassembled and the engine pan removed, it is recommended that the "hard" oil seal 9639 003 1743 be installed in place of the soft oil seal 9639 010 1743 **before** the engine pan is refitted.

Important:

Do not use a press to install the hard oil seal 9639 003 1743. Install **hard** oil seals as described in 6.7

Install in the reverse sequence.

6.4 Shroud

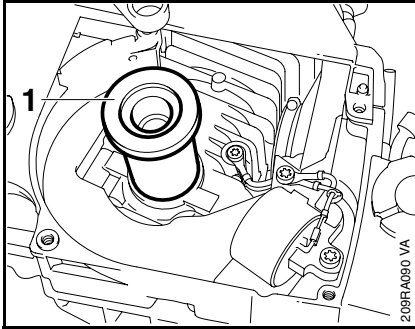

- Use press sleeve (1) 1127 893 2400 to install the “soft” oil seal.
- Wait about one minute, then rotate the crankshaft.
- Install the flywheel, 7.3

Install all other parts in the reverse sequence.

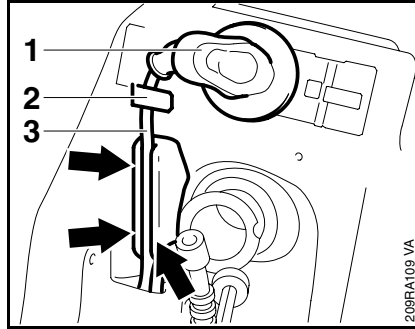

- Pull off the spark plug boot (1).
- Pull the ignition lead (3) out of the retainer (2) and guides (arrows).

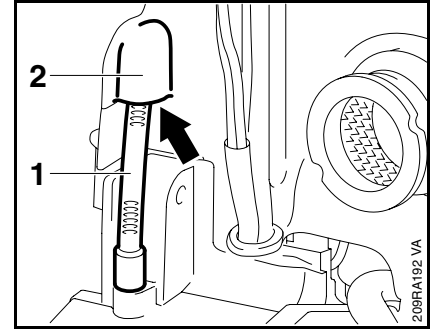

Machines up to 2001

- Push the tank vent (1) into its seat (arrow) in the shroud (2).

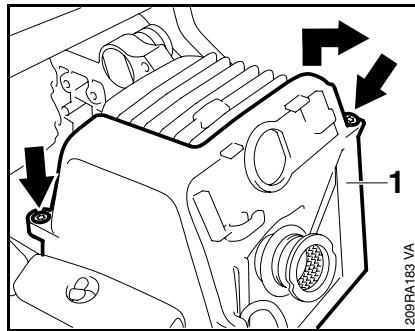

- Take out the screws (arrows).
- Lift the shroud (1) up a little and remove it to the rear.

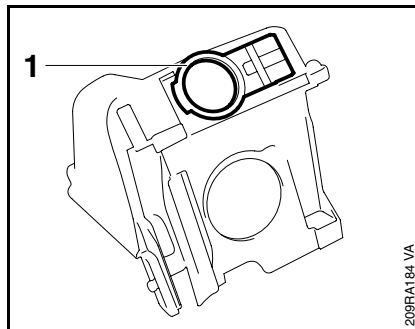





- If necessary, unclip the shutter (1).

Install in the reverse sequence.

6.5 Removing and Installing the Engine

Always check and, if necessary, repair the fuel system, carburetor, air filter and ignition system before looking for faults on the engine.

- Remove the handle housing,  9.2
- Remove the shroud,  6.4
- Remove the oil pump,  10.4.1
- Remove the muffler,  6.1
- Remove the flywheel,  7.3

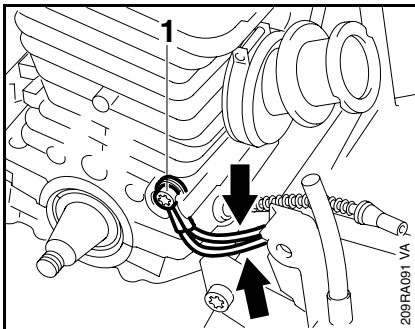

- Take out the screw (1).
- Remove the ground wires (arrows).

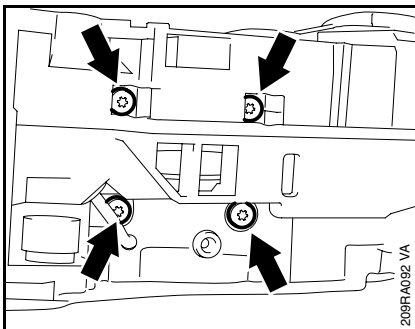

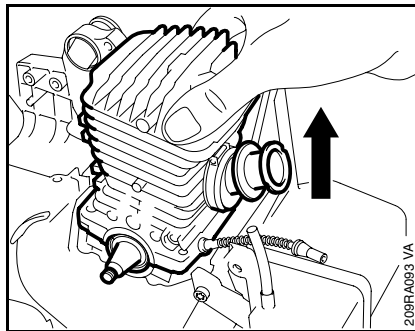

- Take out the screws (arrows).





- Set piston to bottom dead center.
- Lift cylinder with crankshaft upwards and off the engine pan.
- Remove cylinder sideways from the engine housing.
- For other operations see  6.5.1

Install in the reverse sequence.

- Tighten down the engine pan/cylinder mounting screws in alternate pattern,  3.5
- Tighten down the ground wire fastening screw firmly,  3.5

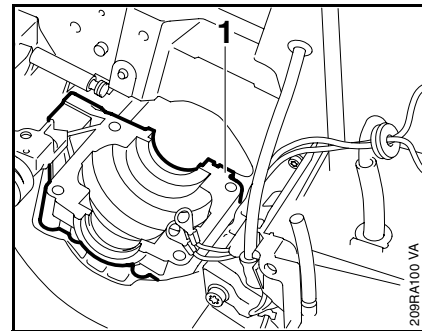

If the engine pan is damaged, it must be replaced **before** installing the cylinder. Perform the following operations to replace the engine pan:



- Unscrew the collar stud,  5.4

- Remove the engine pan (1).

Install in the reverse sequence.

- Fit the engine pan in the engine housing.
- Coat the thread of the collar stud with Loctite,  13.
- Insert and tighten down the collar stud firmly,  3.5
- For other operations see  6.5.1

6.5.1 Cylinder

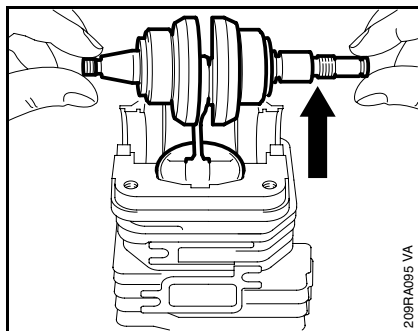

The cylinder can be removed without having to take the engine pan out of the housing.

– Remove the engine, [13](#) 6.5

- Lift the crankshaft and pull the piston out of the cylinder at the same time.

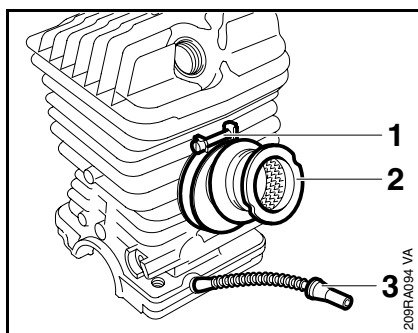

- Loosen the clamp (1).
- Pull the manifold (2) off the intake port.
- Disconnect the impulse hose (3).

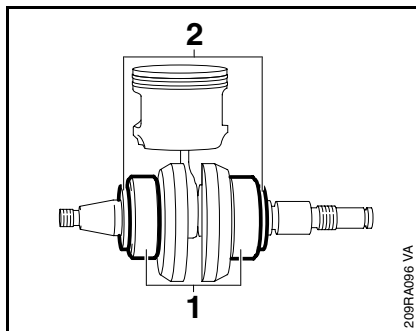

- Remove the oil seals (2).
 - Inspect ball bearings (1) and replace if necessary, [13](#) 6.7
- Inspect the cylinder and crankshaft for damage and replace if necessary.
- Inspect the piston and piston rings for damage and replace if necessary, [13](#) 6.5.2

If a new cylinder has to be installed, always fit the matching piston with piston rings.

- Thoroughly clean all residue of sealant from the cylinder and engine pan mating faces.

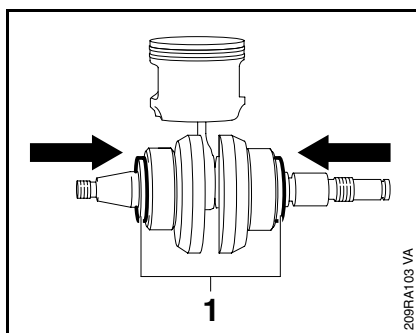

- Push oil seals (1) into position.
- Apply a thin coating of sealant to the outer diameters of the oil seals, [13](#) 13.

- Lubricate piston and piston rings with oil.

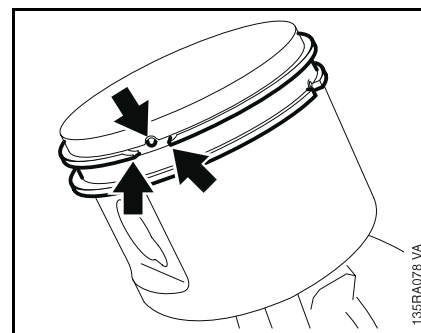

- Position the piston rings so that the radii at the ring gap meet at the fixing pin in the piston groove when the rings are compressed.

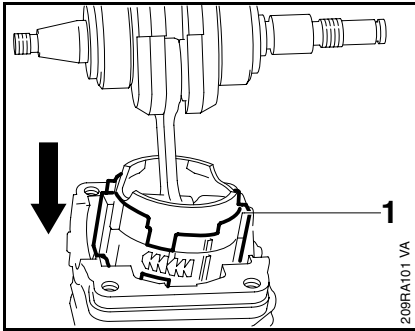

- Compress the piston rings with clamping strap (1) 1127 893 2602.
- Push the piston carefully into the cylinder.
- Remove the clamping strap (1).

– Push the crankshaft home until the ball bearings are seated.

Make sure that ball bearings and oil seals are correctly seated.

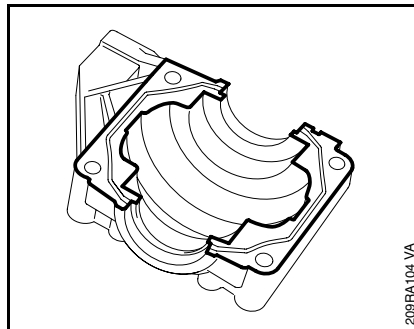

- Apply a thin bead of sealant to the groove in the engine pan mating face,  13.

Follow manufacturer's instructions.

- If necessary, install the engine pan,  6.5

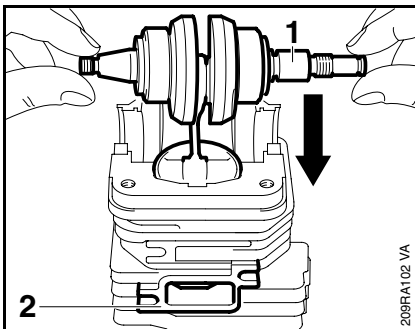

- Position the crankshaft so that the long crankshaft stub (1) points to the right, looking at exhaust port (2).

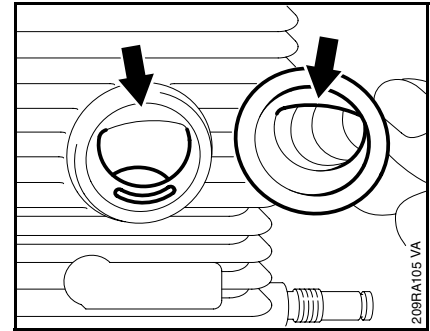

- Push the manifold on to the intake port so that the straight faces (arrows) are in alignment.

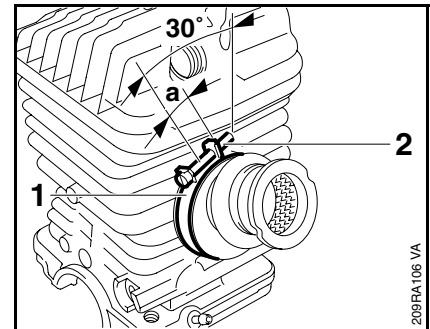

- Fit clamp (1) with its ends facing up at an angle of 30° to the left.
- Tighten down the clamp (1) until its ends butt against the sleeve (2) or the gap "a" is 6 to 7 mm.

If a new cylinder is installed, also install a new piston,  6.5.2

6.5.2 Piston

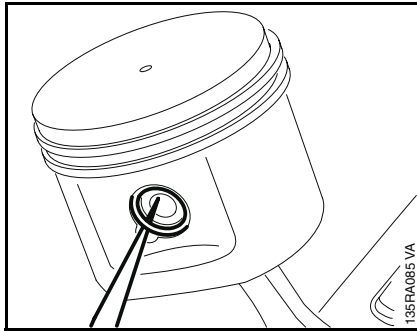

- Pull the piston out of the cylinder, 6.5.1
- Ease the hookless snap rings out of the grooves.

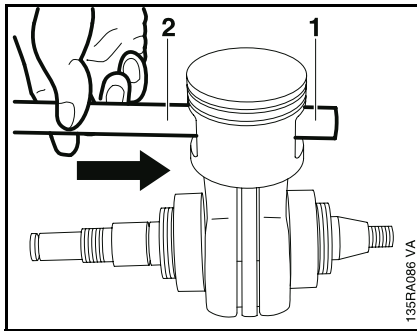

- Use the assembly drift (2) 1110 893 4700 to push the piston pin (1) out of the piston.

If the piston pin is stuck, release it by tapping the end of the drift **lightly** with a hammer. Hold the piston steady during this process to ensure that no jolts are transmitted to the connecting rod.

- Remove the piston from the connecting rod.
- Inspect needle cage and replace if necessary.

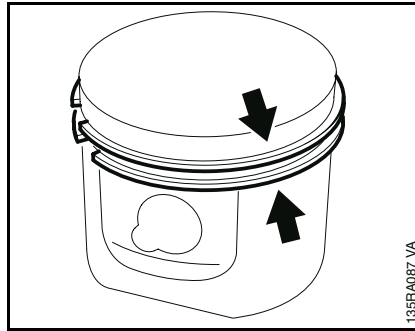

- Inspect piston rings and replace if necessary, 6.6

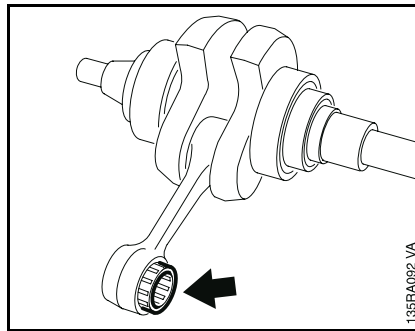

- Fit needle cage (arrow) in the connecting rod.
- Lubricate needle cage with oil.

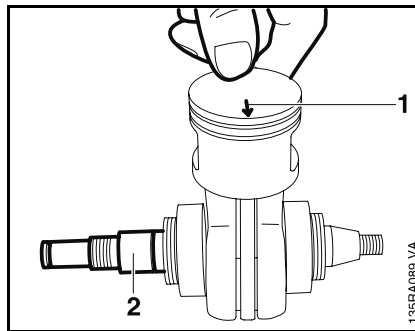

- Push the piston over the connecting rod.

Installed position of piston:

- 1 = Mark (arrow)
- 2 = Long stub of crankshaft

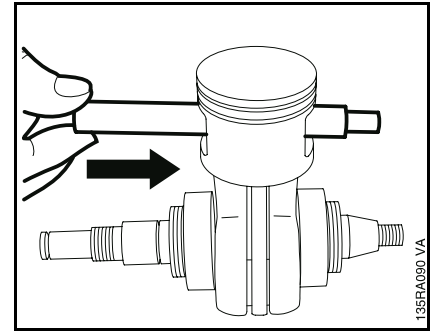

- Push the assembly drift, small diameter first, through the piston and small end (needle cage) and line up the piston.

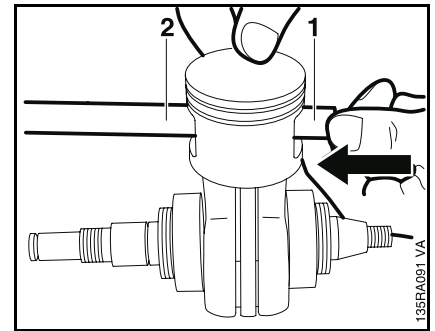

- Fit the piston pin (1) on the assembly drift (2) and slide it into the piston (the pin slides home easily if the piston is warm).

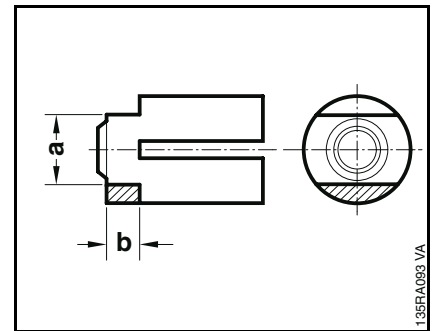

- If necessary, modify the sleeve of the installing tool 5910 890 2210 as shown:

- a = 16 mm
- b = 8 mm

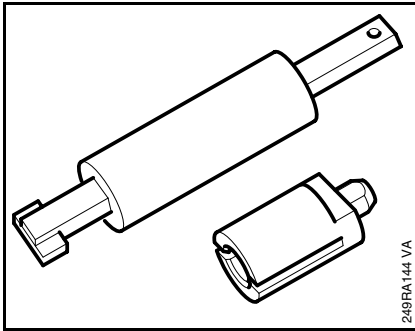

- Remove the sleeve from the tool.

– Wear safety glasses –

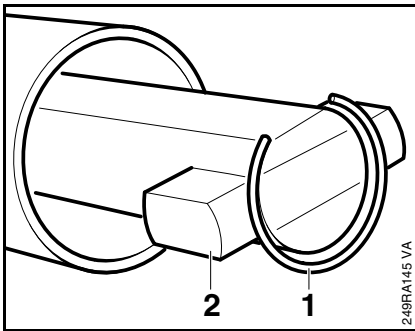

- Attach the snap ring (1) to the magnet (2) so that the snap ring gap is on the flat side of the tool's shank.

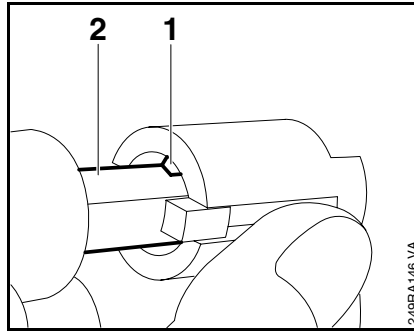

- Push the large slotted diameter of the sleeve over the magnet and snap ring. Position the sleeve so that the inner pin (1) points toward the flat face (2) of tool's shank.

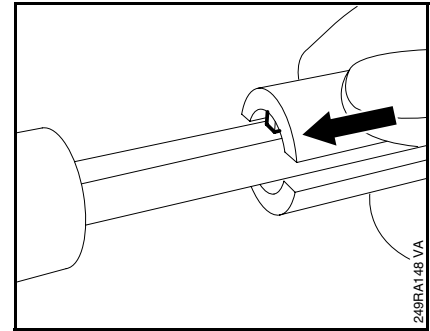

- Remove the sleeve and slip it onto the other end of the shank.

Inner pin must again point toward flat face.

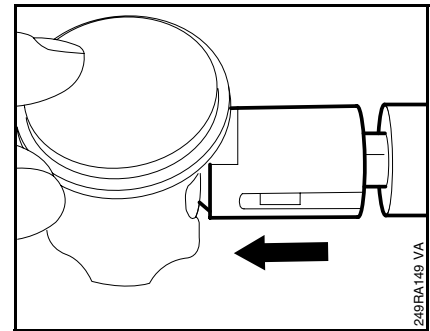

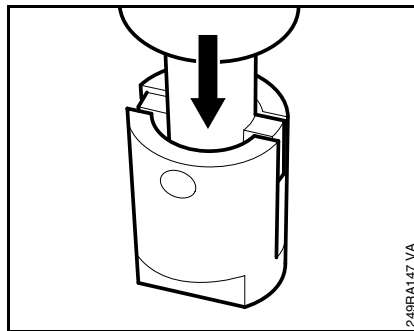

- Apply the installing tool to the piston boss, hold the piston steady, center the tool shank exactly and press home until the snap ring slips into the groove.

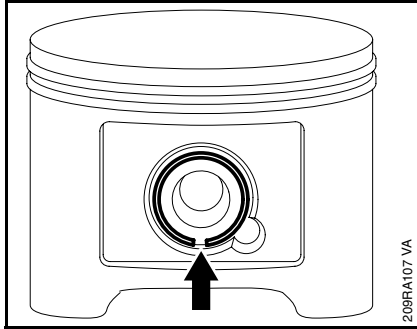

- Stand the installing tool, sleeve downward, on a flat surface (wooden board) and press vertically downwards until the sleeve butts against the tool's shoulder.

6.6 Piston Rings



- Fit the snap rings so that their gaps are on the piston's vertical axis (they must point either up or down – see arrow).
- Install the piston,  6.5.1

Install all other parts in the reverse sequence.

- Pull the piston out of the cylinder,  6.5.1
- Remove rings from the piston.

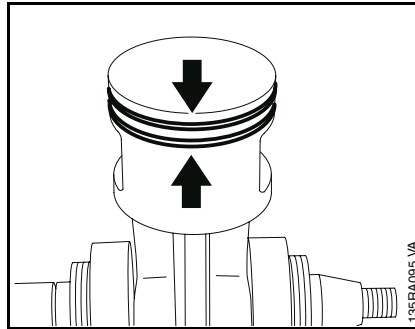

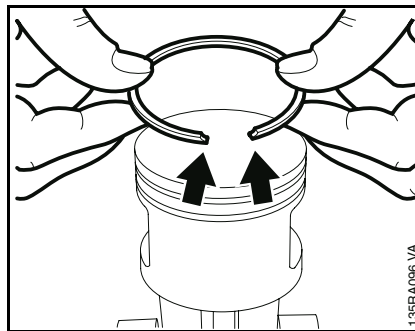

- Use a piece of old piston ring to scrape the grooves clean.

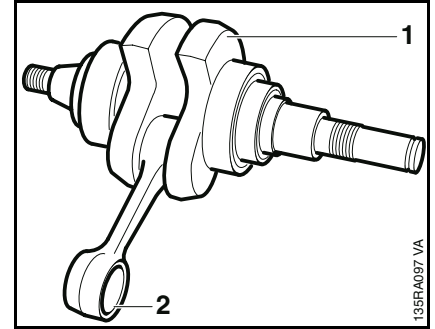

- Install the new piston rings in the grooves so that the radii face upward.
- Install the piston,  6.5.1

6.7 Crankshaft



- Remove the piston,  6.5.2
- The crankshaft (1) and connecting rod (2) form an inseparable unit. This means the crankshaft must always be replaced as a complete unit.

When fitting a replacement crankshaft, always install new ball bearings, oil seals and needle bearing.

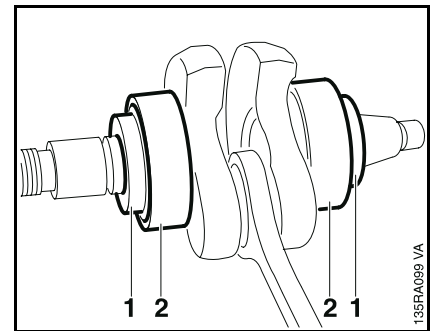

- Pull off the oil seals (1) and ball bearings (2).

Install in the reverse sequence.

7. Ignition System

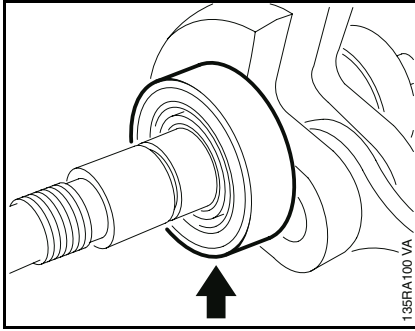

- Heat ball bearing to approx. 50°C and, with closed side facing outwards, push it on to the crankshaft stub as far as stop.

When the crankshaft is removed, it is recommended that the “**hard**” oil seals 9639 003 1743 be installed in place of the “**soft**” oil seals 9639 010 1743.

Note

The “**hard**” oil seals may be installed on the crankshaft only when it is removed from the engine. The “**soft**” oil seals **must** be used if the crankshaft is in the installed condition.

- Lubricate sealing lips of oil seals with grease,  13.

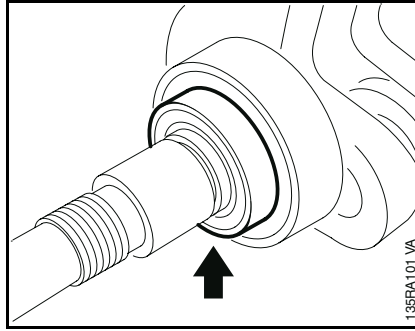

- Slide oil seals over the crankshaft stubs so that their open sides are facing the ball bearings (arrow).

Install all other parts in the reverse sequence.

Exercise extreme caution when troubleshooting and carrying out maintenance or repair work on the ignition system. The high voltages which occur can cause serious or even fatal accidents!

Troubleshooting on the ignition system should always begin at the spark plug,  4.4

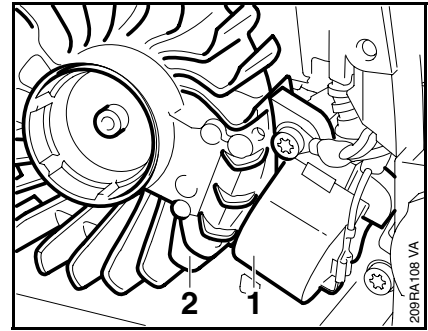

The electronic (breakerless) ignition system basically consists of an ignition module (1) and flywheel (2).

7.1 Ignition Module

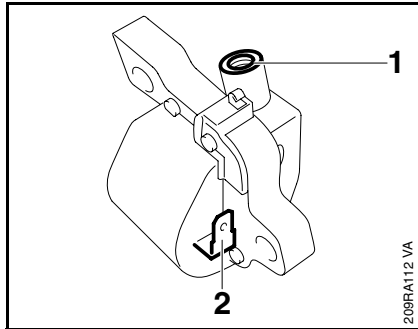

The ignition module accommodates all the components required to control ignition timing. There are two electrical connections on the coil body:

- High voltage output for ignition lead (1)
- Connector tag (2) for the short circuit wire

Testing in the workshop is limited to a spark test.

A new ignition module must be installed if no ignition spark is obtained (after checking that wiring and stop switch are in good condition)..

7.1.1 Ignition Timing

Ignition timing is fixed and cannot be adjusted during repair or servicing work

Since there is no mechanical wear in these systems, ignition timing cannot get out of adjustment as a result of wear.

7.1.2 Removing and Installing

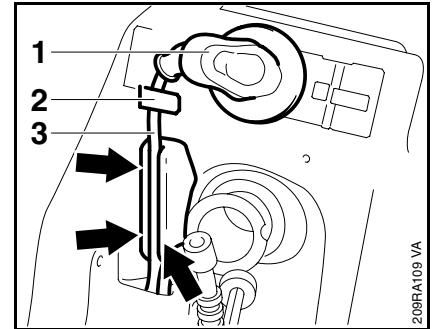

– Remove the handle housing,  9.2

- Pull the spark plug boot (1) off the spark plug.
- Pull ignition lead (3) out of retainer (2).
- Pull the ignition lead (3) out of the guide (arrows).

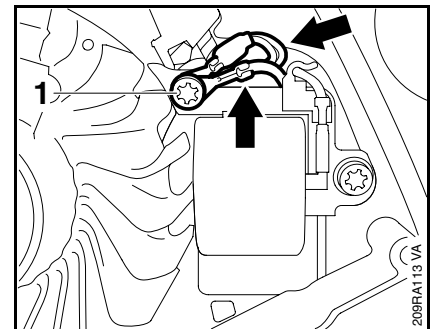

- Take out the screw (1) and remove the ground wires (arrows).

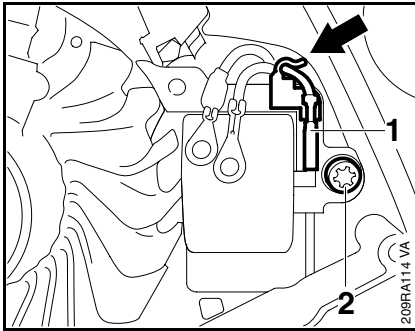

- Disconnect the short circuit wire (1) and pull it out of the retainer (arrow).
- Remove the screw (2) with washer.

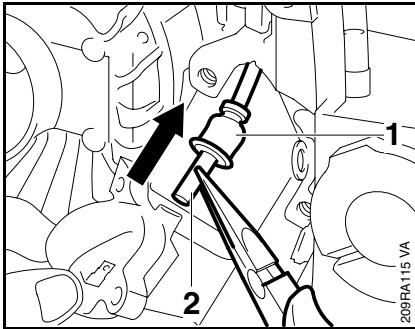

- Pull the ignition module downwards.
- Push the grommet (1) upwards.
- Unscrew the ignition lead (2) from the module.
- Remove the ignition module.

If the ignition lead or spark plug boot is damaged, install new parts,  7.2

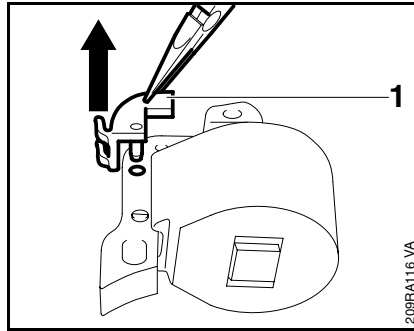

- If necessary, pull the retainer (1) out of the ignition module.
- Install in the reverse sequence.

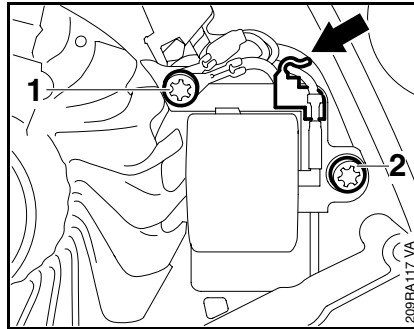

- Fit screw (1) with ground wires but do not tighten down yet.
- Fit screw (2) with washer but do not tighten down yet.
- Push short circuit wire into wire retainer (arrow).

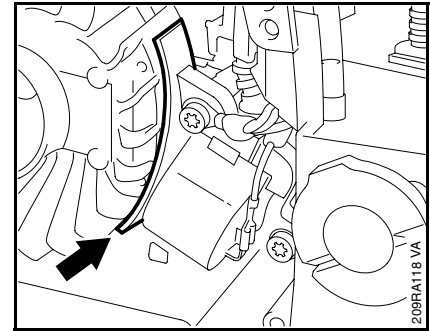

- Rotate the flywheel until its raised edge (arrow) is in line with the ignition module.

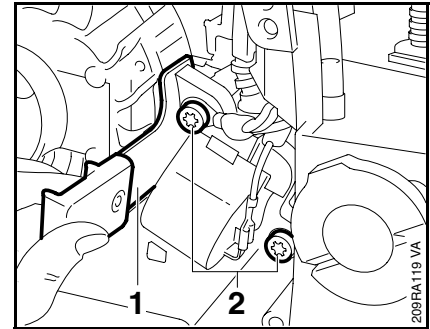

- Loosen the screws (2).
- Slide the setting gauge (1) 1111 890 6400 between the arms of the ignition module and the raised edge of the flywheel.
- Press the ignition module against the setting gauge.

7.1.3 Testing the Ignition Module

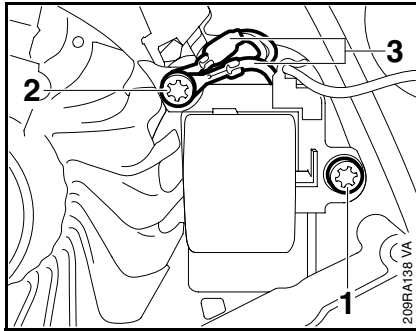

- Tighten down the screw (1) firmly, 3.5
 - Make sure the crimp connections of the ground wires (3) are next to one another.
 - Tighten down the screw (2) firmly, 3.5
- Remove setting gauge and use a feeler gauge to check the air gap. It should be 0.15 - 0.3 mm.

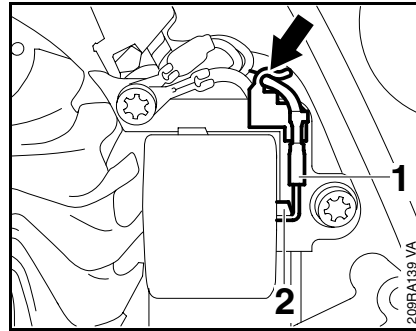

- Fit short circuit wire (1) on tag (2) so that crimping faces the engine housing.
- Clip the short circuit wire (1) to the retainer (arrow).

Install all other parts in the reverse sequence.

To test the ignition module, use either the ZAT 4 ignition system tester 5910 850 4503 or the ZAT 3 ignition system tester 5910 850 4520.

The ignition test refers only to a spark test, not to ignition timing.

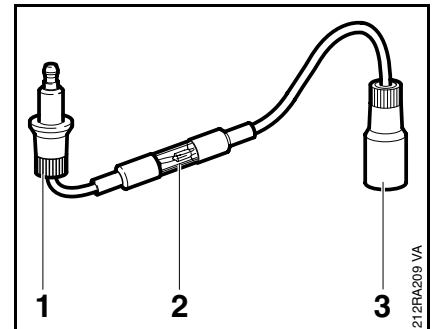

Using the ZAT 4 ignition tester 5910 850 4503

- Before starting the test, install a new spark plug in the cylinder and tighten it down firmly, 3.5
- Remove spark plug boot and connect it to the input terminal (1). Push the tester's output terminal (3) onto the spark plug.
- Crank the engine quickly with the rewind starter (min. 1,000 rpm) and check spark in the tester's window (2).

Warning!

The engine may start and accelerate during the test.

If a spark is visible, the ignition system is in order. If no spark is visible in the window (2), check the ignition system with the aid of the troubleshooting chart, 7.6

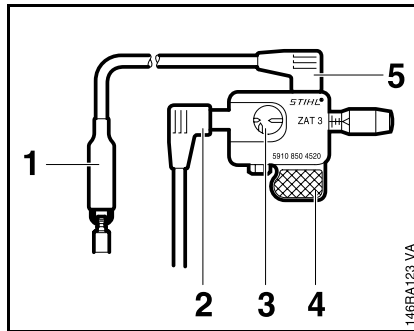

While using the ZAT 3, hold it only by the handle (4) or position it in a safe place. Keep fingers or other parts of your body at least 1 cm away from the spark window (3), high voltage connection (2), ground connection (5) and the ground terminal (1).

Warning!

High voltage – risk of electrocution.

- Crank the engine quickly with the rewind starter (min. 1,000 rpm) and check sparkover in the tester's window (3).

Warning!

The engine may start and accelerate during the test.

If a spark is visible, the ignition system is in order.

If no spark is visible in the window (3), check the ignition system with the aid of the troubleshooting chart, 7.6

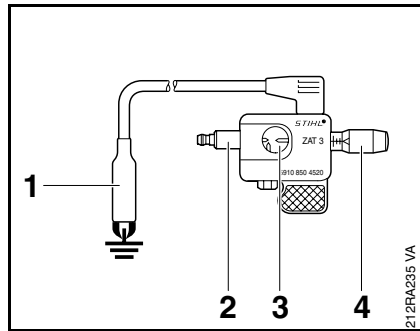

Using the ZAT 3 ignition tester 5910 850 4520

- Before starting the test, install a new spark plug in the cylinder and tighten it down firmly, 3.5
- Remove spark plug boot and connect it to terminal (2).
- Attach ground terminal (1) to the spark plug.
- Use adjusting knob (4) to set spark gap to about 2 mm.
- If a spark is visible in window (3), the ignition system is in order.

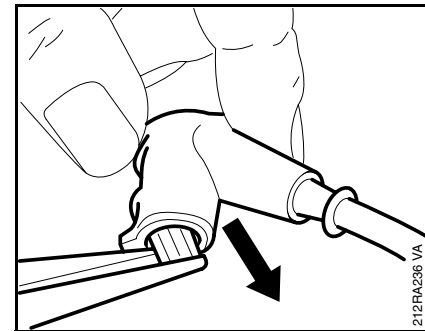

- Troubleshooting – 4.4
- Remove the handle housing, 9.2
- Pull the boot off the spark plug.
- Use suitable pliers to pull the leg spring out of the spark plug boot.
- Unhook the leg spring from the ignition lead.
- Pull the boot off the ignition lead.
- Cut new ignition lead to a length of 175 mm.
- Coat end of ignition lead (about 20 mm) with oil.
- Fit the spark plug boot over the ignition lead.

Install in the reverse sequence.

7.2.1 Ignition Lead

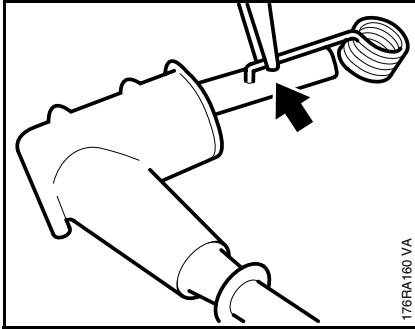

- Use a pointed tool to pierce the center of the ignition lead's insulation, about 15 mm from the end of the lead.
- Pinch the hook of the leg spring into the center of the lead (arrow).

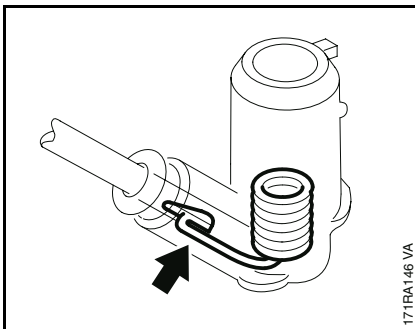

- Pull the lead back into the spark plug boot so that the leg spring locates properly inside it (arrow).

Install all other parts in the reverse sequence.

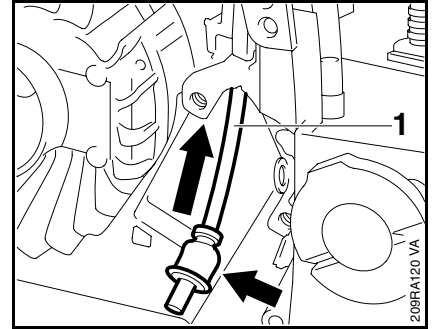

- Troubleshooting – 4.4
- Remove the ignition module, 7.1.2
- Pull the grommet (arrow) downwards and off the ignition lead.
- Pull the ignition lead (1) upwards and out of the tank housing.
- Remove the spark plug boot, 7.2

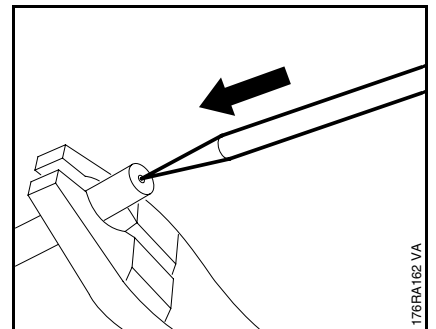

Install in the reverse sequence.

- Cut new ignition lead to a length of 175 mm.



- Use a pointed tool to pierce the center of the other end of the ignition lead which screws into the module.

7.3 Flywheel

- Remove the fan housing with rewind starter,  8.2
- Use locking strip to block the piston 0000 893 5903,  5.5

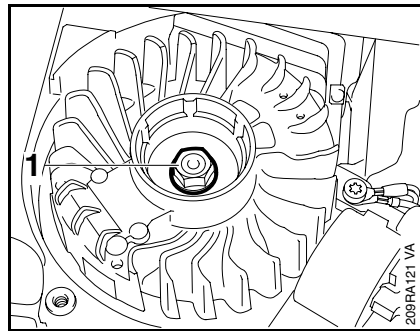

- Unscrew the flywheel nut (1).

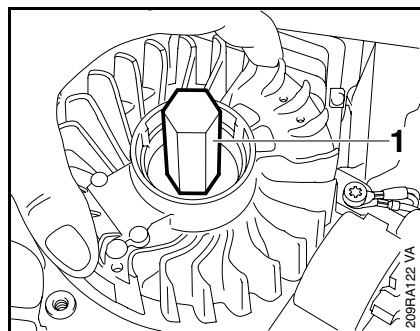

- If the flywheel cannot be removed by hand, screw the puller (1) 1116 893 0800 onto the crankshaft stub.

- Use a suitable tool to tap the end of the puller to release the flywheel.

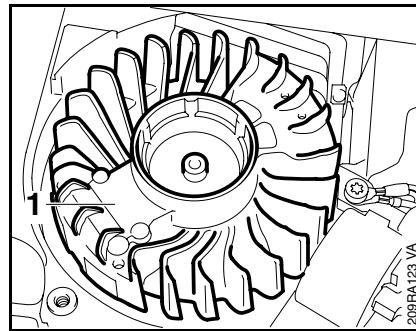

- Unscrew the puller.
- Remove the flywheel (1).

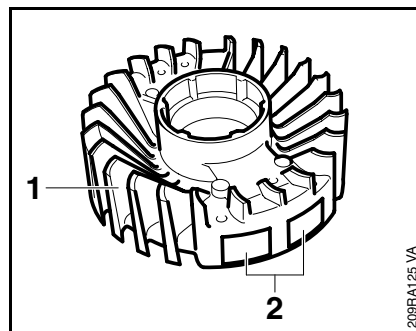

- The flywheel (1) and magnet poles (2) must not be damaged or have turned blue. Replace flywheel if necessary.

- Degrease crankshaft stub and bore in flywheel with standard solvent-based degreasant containing no chlorinated or halogenated hydrocarbons,  13.

Install in the reverse sequence.

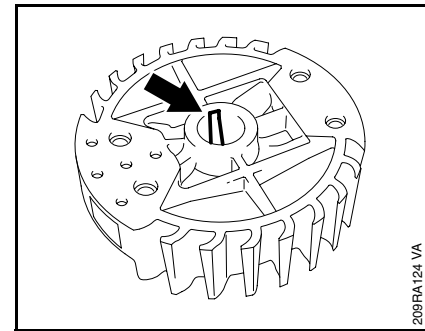

- Make sure the machined key (arrow) engages the slot in the crankshaft.
- Check air gap between ignition module and flywheel and adjust if necessary,  7.1.2

Install all other parts in the reverse sequence.

7.4 Contact Spring

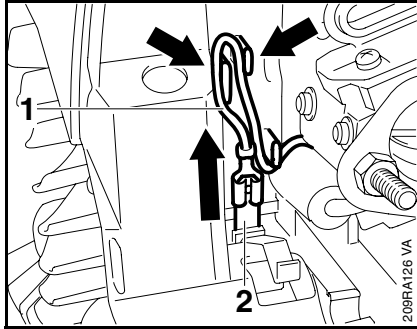

- Remove the switch shaft, [9.4](#)
- Take the short circuit wire (1) out of the guide (arrows) and pull it off the contact spring (2).

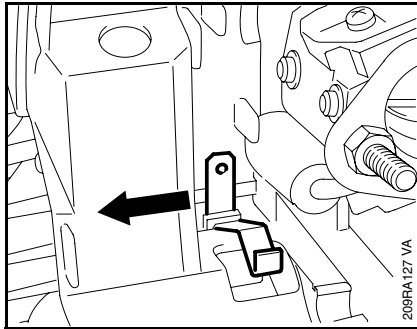

- Ease the contact spring forwards and carefully pry it sideways out of the housing.

Install in the reverse sequence.

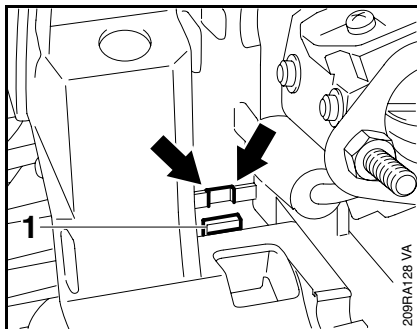

- When fitting, make sure the contact spring is under the guide pin (1) and locates in the housing recess (arrows).

7.5 Replacing Wiring Harness

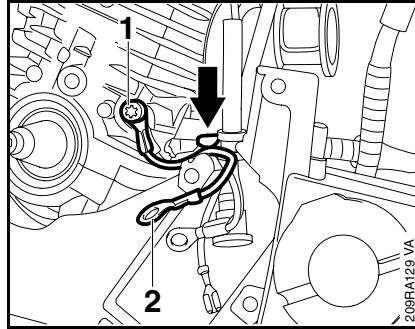

- Remove the handle housing, [9.2](#)
- Remove the flywheel, [7.3](#)
- Remove the ignition module, [7.1.2](#)
- Remove the shroud, [6.4](#)

- Take out the screw (1).
- Pull the ground wire (2) out of the retainer (arrow) and remove it.

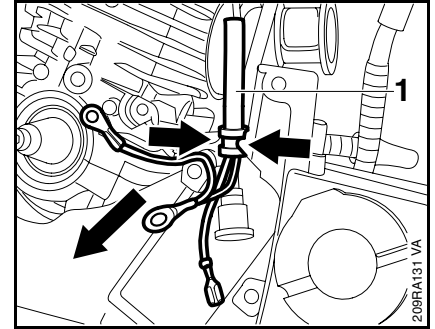

- Pull the wiring harness (1) out of the retainer (arrows) in the engine housing.

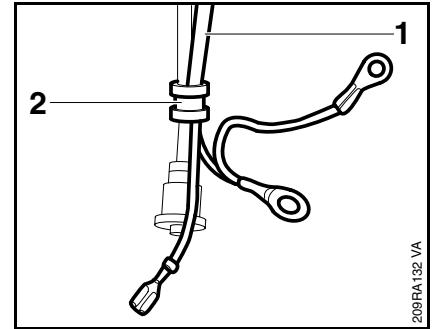

- Pull the wiring harness (1) out of the grommet (2).
- Inspect the wiring harness and ignition lead for signs of damage and replace if necessary.

Install in the reverse sequence.

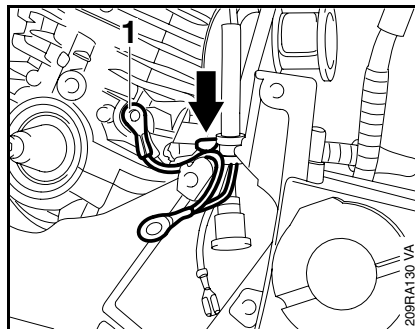

- Pull the wire (1) out of the retainer (arrow).

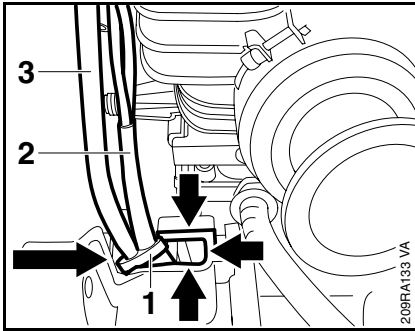

When installing, push grommet (1) sideways into the housing recess (arrows). The wiring harness (2) must be on the right of the ignition lead (3).

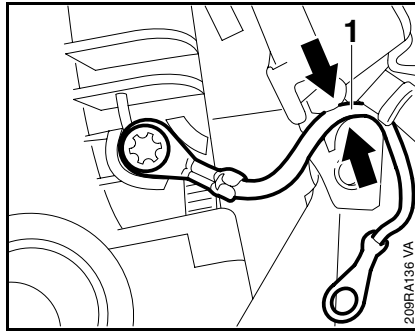

- Push additional ground wire (1) into the retainer (arrows).
- Position the cable lug against the cylinder with its crimping facing outwards.

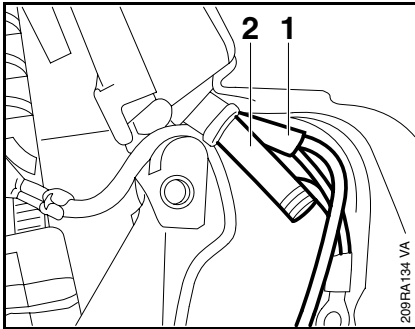

- Position the wiring harness (1) under the ignition lead (2).

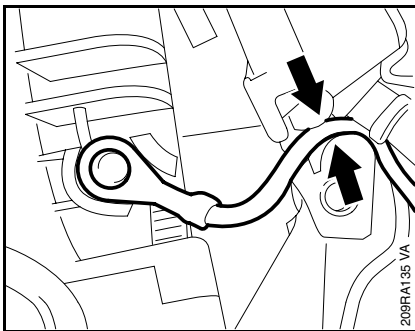

- Push the ground wire into the retainer (arrows).
- Position the cable lug against the cylinder with its crimping facing the cylinder.

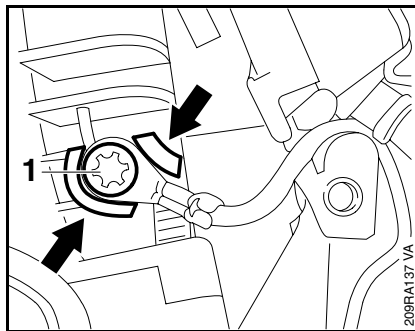

- Fit the ground wires between the guide lugs (arrows) and line them up.
- Fit the screw (1) and tighten it down firmly, 3.5

– Install the ignition module, 7.1.2

Install all other parts in the reverse sequence.

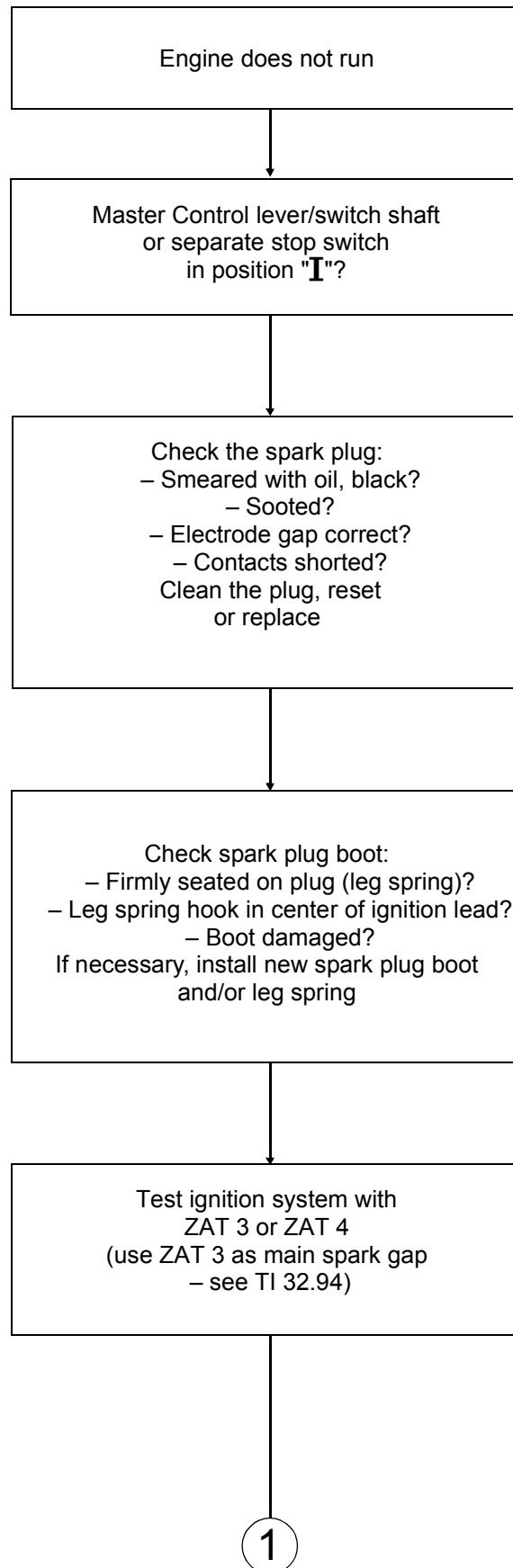

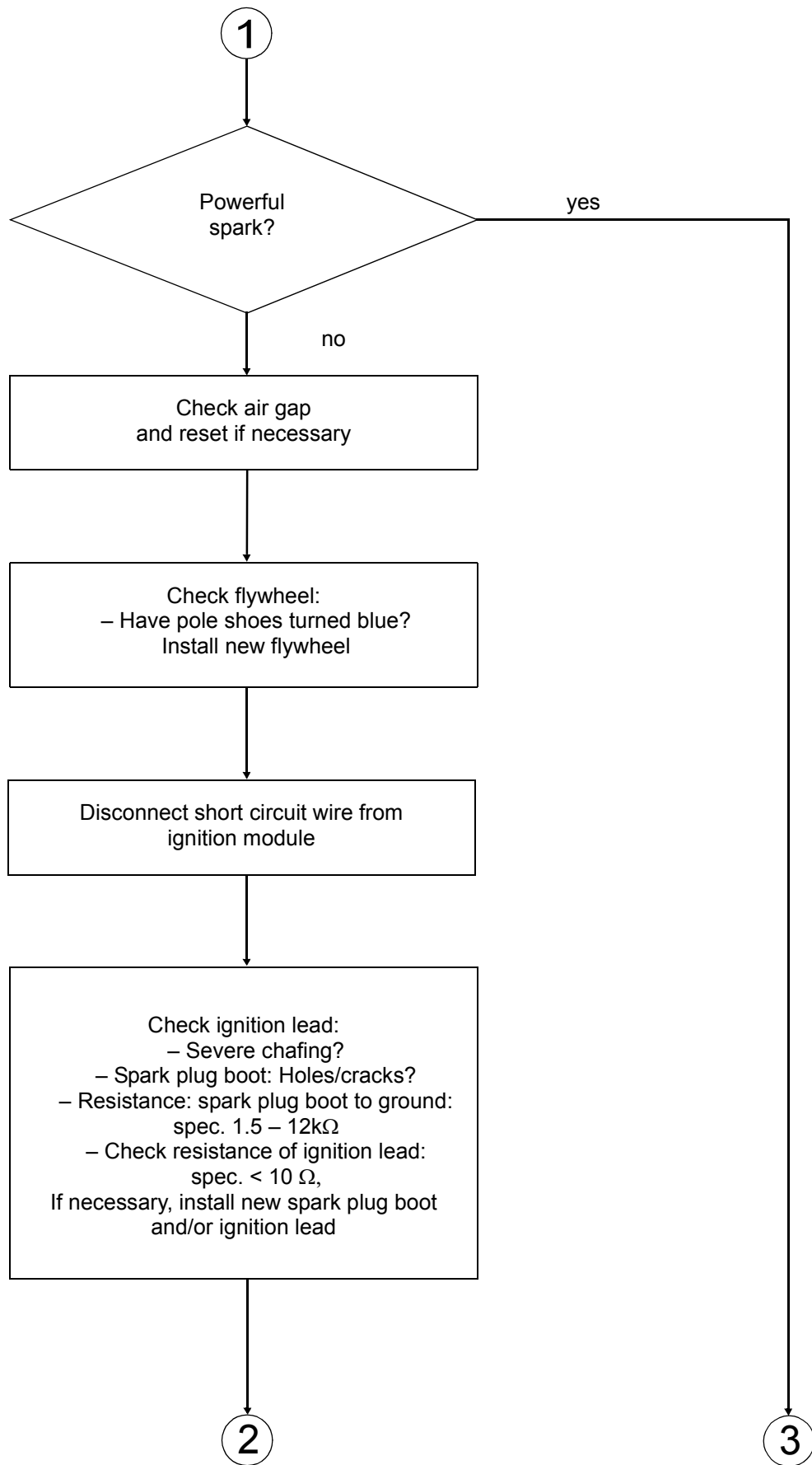

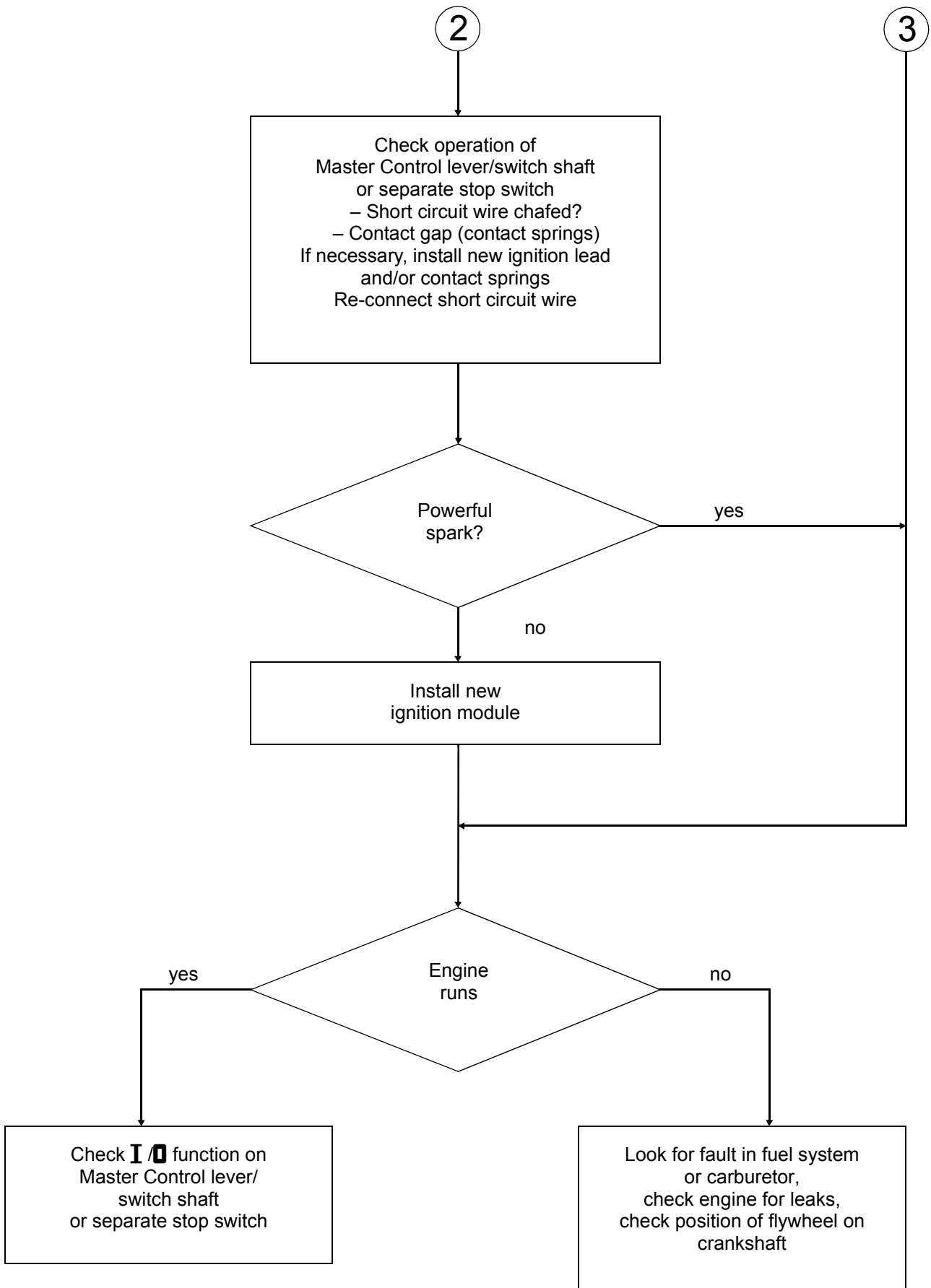

8. Rewind Starter

8.1 General

If the action of the starter rope becomes very stiff and the rope rewinds very slowly or not completely, it can be assumed that the starter mechanism is in order but plugged with dirt. At very low outside temperatures the lubricating oil on the rewind spring may thicken and cause the spring windings to stick together. This has a detrimental effect on the function of the starter mechanism. In such a case it is sufficient to apply a few drops of a standard solvent-based degreasant (containing no chlorinated or halogenated hydrocarbons) to the rewind spring.

Carefully pull out the starter rope several times and allow it to rewind until its normal smooth action is restored.

If clogged with dirt or pitch, the entire starter mechanism, including the rewind spring, must be removed and disassembled. Take particular care when removing the spring.

Clean all components,  13.

Before installing, lubricate the rewind spring and starter post with STIHL special lubricant,  13.

8.2 Removing and Installing

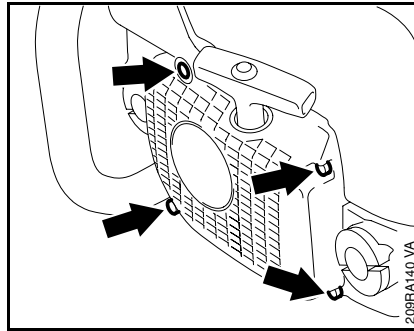

- Take out the screws (arrows).
- Carefully push the hand guard upwards.
- Pull the underside of the fan housing away from the engine housing and remove it downwards.

Install in the reverse sequence.

The hand guard is secured to the fan housing and engine housing with an IS-D5x24 screw and sleeve.

- Tighten down the screws firmly,  13.

8.3 Pawl

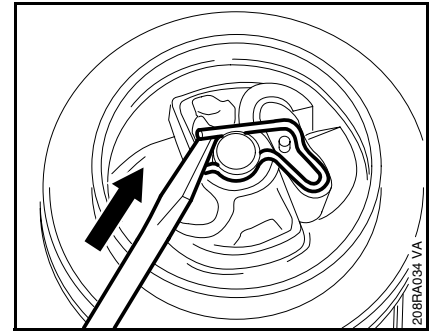

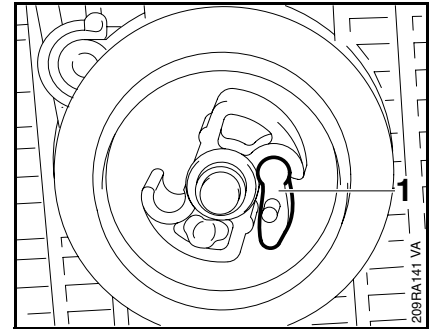

- Remove the fan housing with rewind starter,  8.2
- Carefully remove the spring clip from the starter post.



- Pull the pawl (1) out of the rope rotor.
- Lubricate peg of new pawl with grease,  13.

Install in the reverse sequence.

8.4 Rope Rotor

- Troubleshooting –  4.2
- Remove the fan housing,  8.2

Relieving tension of rewind spring

The rewind spring will not be under tension if the starter rope is broken

- Pull out the starter rope about 5 cm and hold the rope rotor steady.
- While still holding the rope rotor steady, take three full turns off the rope rotor.
- Pull out the rope with the starter grip and slowly release the rope rotor.
- Remove the pawl,  8.3

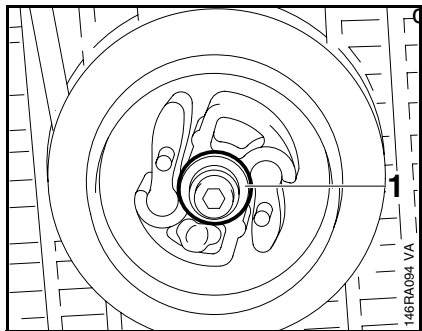

- Remove the washer (1) from the starter post.
- Carefully pull the rope rotor off the starter post.

- Remove the starter rope/ remaining rope from the rotor
- Remove any remaining rope from the fan housing.
- Install a new starter rope,  8.5

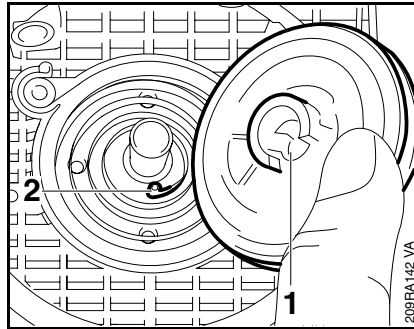

- Fit the rotor on the starter post so that the lug (1) on the rope rotor slips behind the inner spring loop (2).

Install all other parts in the reverse sequence.

- Tension the rewind spring,  8.5.1

8.5 Starter Rope/Grip

- Remove the fan housing with rewind starter,  8.2

Relieving tension of rewind spring

The rewind spring will not be under tension if the starter rope is broken

- Pull out the starter rope about 5 cm and hold the rope rotor steady.
- While still holding the rope rotor steady, take three full turns off the rope rotor.
- Pull out the rope with the starter grip and slowly release the rope rotor.
- Remove the starter rope from the rotor.

Starter grip without ElastoStart

- Remove any remaining rope from the starter grip.

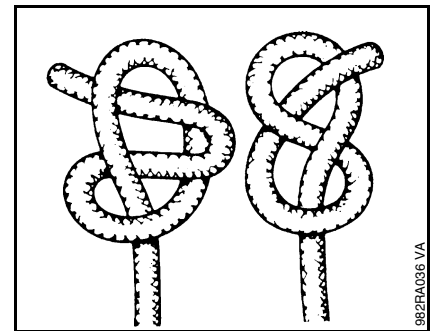

- Tie one of the special knots shown in the end of the starter rope.

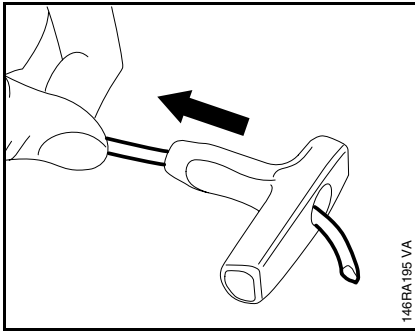

- Thread the new rope through the top of the starter grip.
- Pull the rope with knot into the starter grip.

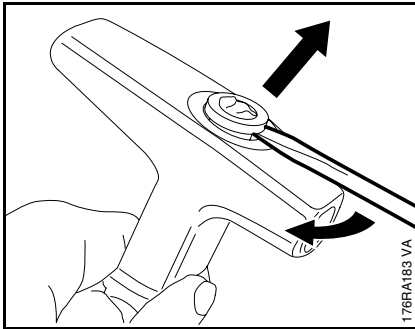

ElastoStart starter grip

- Pry nipple of starter rope out of the starter grip.
- Remove remaining rope from the starter grip.

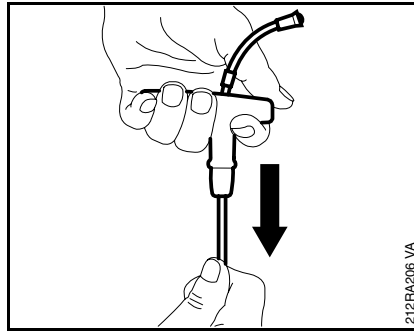

- Thread the new rope through the top of the starter grip.

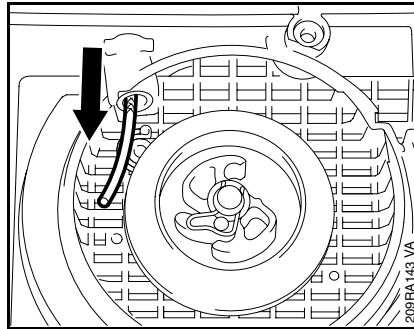

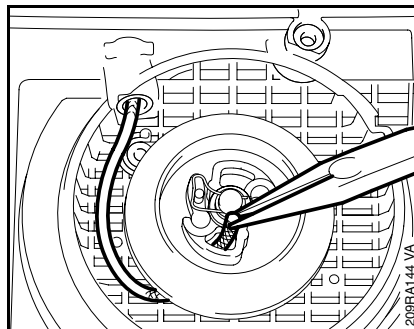

All versions

- Thread the other end of the rope, from outside, through the guide bushing in the fan housing.



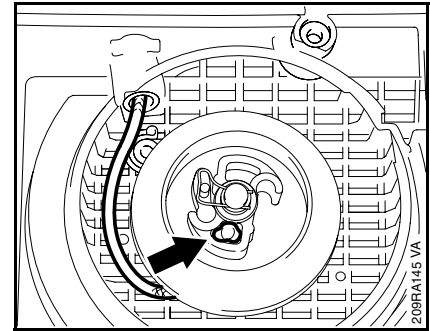

- Thread end of rope through hole in the side of the rotor, pull it out.



- Secure the rope with a simple overhand knot.
- Pull the rope back until the knot locates in the rotor's recess.
- Tension the rewind spring,  8.5.1

8.5.1 Tensioning

- Remove the fan housing with rewind starter,  8.2
- Relieve tension of rewind spring,  8.4

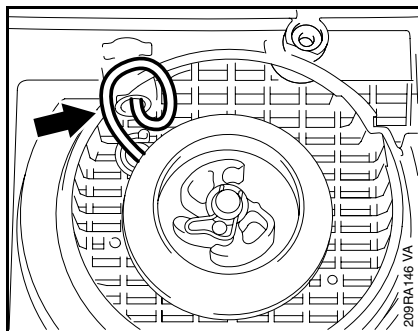

- Make a loop in the starter rope.

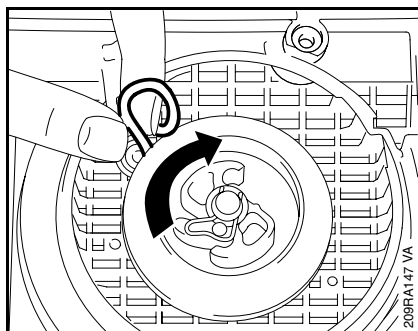

- Grip the rope next to the rotor and use it to turn the rope rotor six times clockwise.

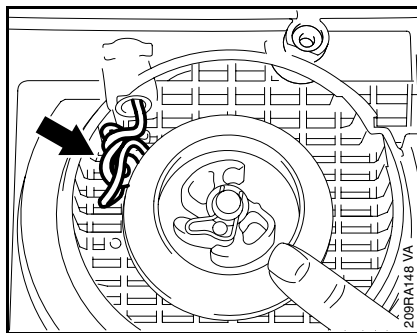

- Hold the rope rotor steady.
- Pull out the rope with the starter grip and straighten it out.
- Hold the starter grip firmly to keep the rope tensioned.
- Let go of the rope rotor and slowly release the starter rope so that it can rewind properly.

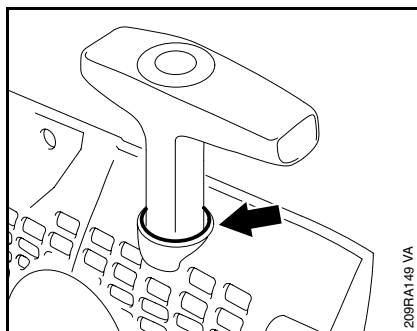

The rewind spring is correctly tensioned when the starter grip sits firmly in the rope guide bushing (arrow) without drooping to one side. If this is not the case, tension the spring by one additional turn.



When the starter rope is fully extended, it must still be possible to rotate the rope rotor at least another half turn before maximum spring tension is reached. If this is not the case, pull the rope out, hold the rope rotor steady and take off one turn of the rope.

Do not overtension the rewind spring as this will cause it to break.

- Install fan housing with rewind starter,  8.2

8.6 Starter Rope Guide Bushing

Wear on the guide bushing is accelerated by the starter rope being pulled sideways. The wall of the bushing eventually wears through and the bushing becomes loose.

- Remove fan housing with rewind starter,  8.2
- Remove the rope rotor,  8.4
- Use a suitable tool to pry the damaged bushing out of the fan housing.
- Place the new bushing in the fan housing.

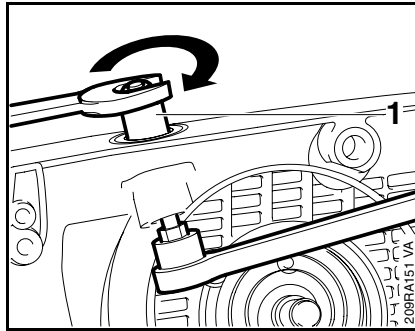

- Fit the thrust sleeve (1), tapered end first, and the hex nut.
- Tighten down the hex nut until the bushing is firmly seated.

The installing tool flares the lower end of the rope bushing.

- Remove the installing tool.

Install all other parts in the reverse sequence.

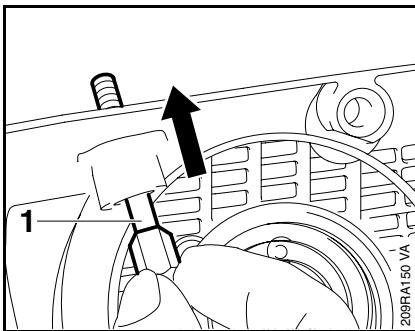

- Insert the screw spindle (1) of the installing tool 0000 890 2201 through the bushing from inside the fan housing.

8.7 Replacing Rewind Spring

- Troubleshooting –  4.2

The replacement spring comes ready for installation and is secured in a frame.

Removing

Wear a face shield and work gloves.

- Remove the rope rotor,  8.4

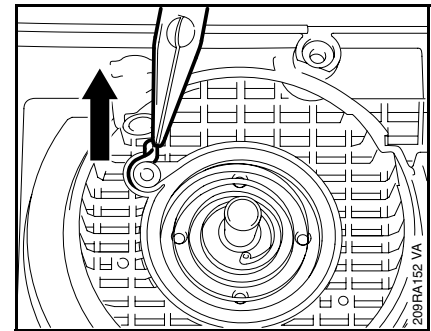

- Use suitable pliers to grip the rewind spring's anchor loop and lift it up.
- Take the rewind spring out of the fan housing.
- Remove any remaining pieces of spring from the fan housing.

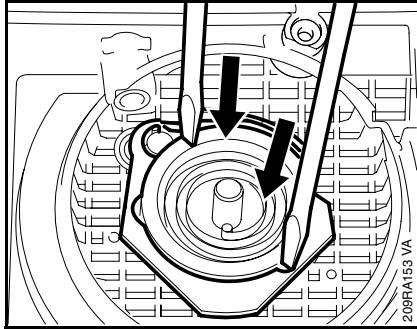

Installing

- Lubricate the spring with a few drops of STIHL special lubricant before installation, 13.
- Position replacement spring with frame in the fan housing.
- Position suitable tools on the recesses (arrows) and push the spring into its seat in the fan housing

If the rewind spring pops out during installation, fit it in the installing tool 1116 893 4800 as follows:

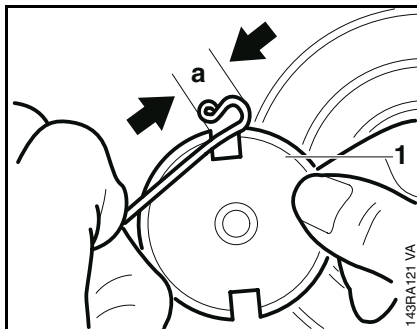

- Position the anchor loop about 20 mm (dimension 'a') from the edge of the installing tool (1).

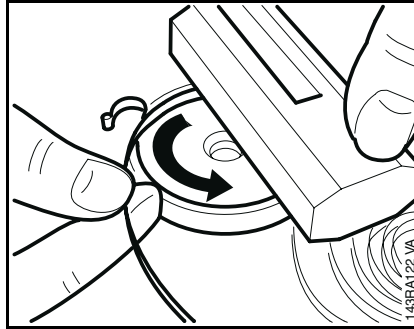

- Fit the rewind spring in the counterclockwise direction, starting from outside and working inwards.
- Place wooden block 1108 893 4800 over the assembly tool to simplify this operation.
- Slip the installing tool with rewind spring over the starter post.
- Push the anchor loop into the recess in the fan housing.
- Install the rope rotor, 8.4

Install all other parts in the reverse sequence.

9. AV Handle System/ Handle Housing Front Handle

9.1

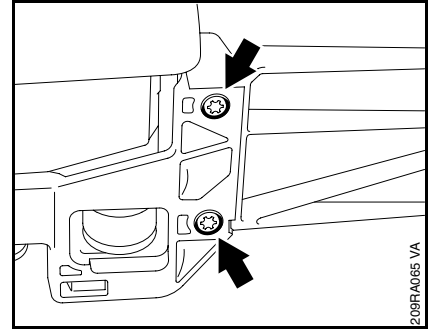

- Take out the screws (arrows).

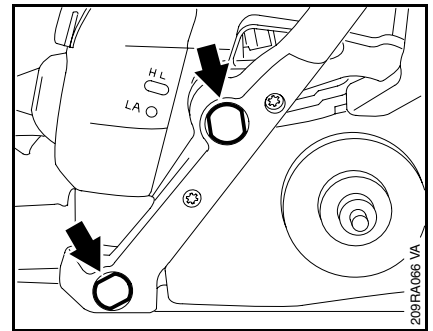

- Pry out the plugs (arrows).

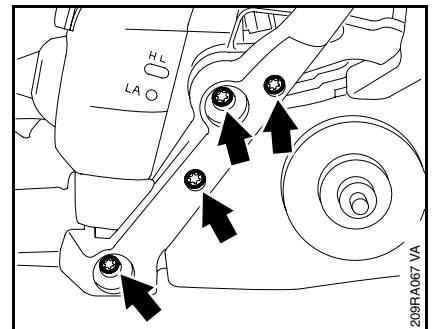

- Take out the screws (arrows).

9.2 Handle Housing

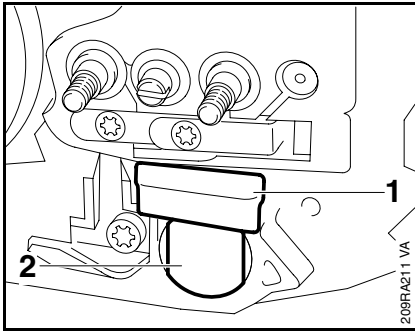

- Pry bumper strip (1) out of housing.
- Remove the plug (2).

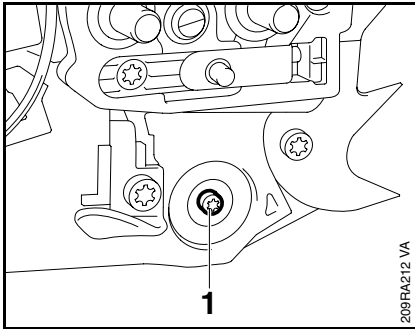

- Take out the screw (1).
- Remove the front handle.
- Replace damaged annular buffers, 9.3.1

Install in the reverse sequence.

- Remove the front handle, 9.1
- Remove the carburetor, 11.2.1
- On machines **up to** 2002 remove the tank vent, 11.5.1
- On machines **from** 2002, remove tank vent valve with hose, 11.5.2

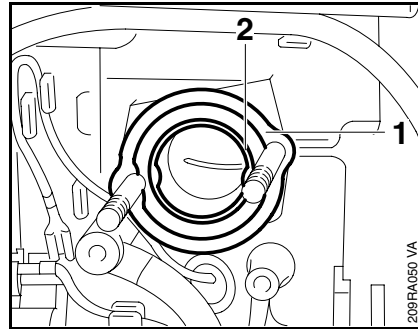

- Remove the sleeve (1).
- Remove the washer (2).

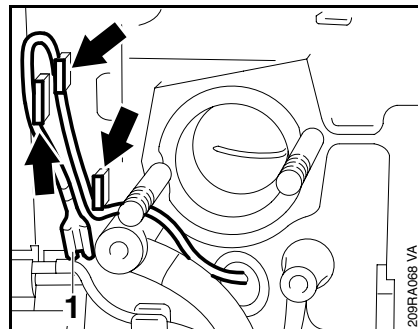

- Pull the ground wire (1) off the contact spring.
- Pull the ground wire out of the retainers (arrows).

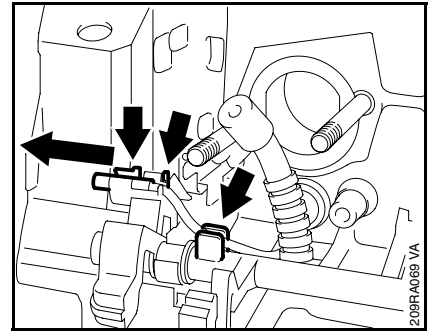

- Disconnect the short circuit wire from the switch shaft by pulling it to the left and take it out of the retainers (arrows).

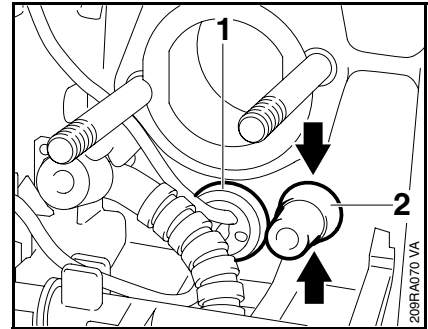

- Push the grommet (1) with wires into the handle housing.
- Carefully squeeze the impulse hose (2) together and push it into the handle housing.

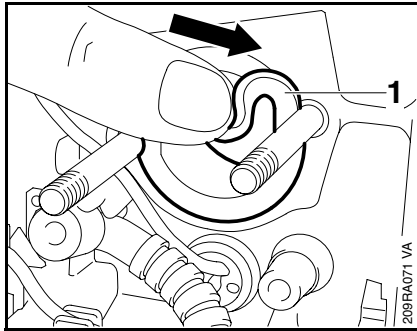

- Push the manifold (1) into the handle housing.

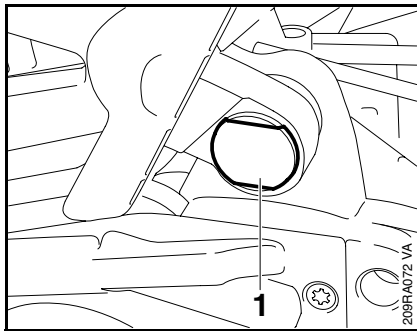

- Pry the plug (1) out of the annular buffer.

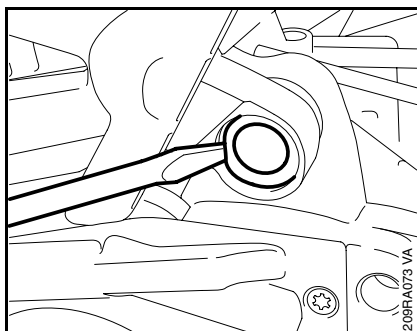

- Ease the annular buffer out of the handle housing.
- Remove the handle housing.

If the handle housing is being replaced because of damage, carry out the following additional operations:

- Remove the switch shaft, 9.4
- Remove the contact spring, 7.4
- Remove the throttle trigger/interlock lever, 9.5
- Replace damaged annular buffers, 9.3

Install in the reverse sequence.

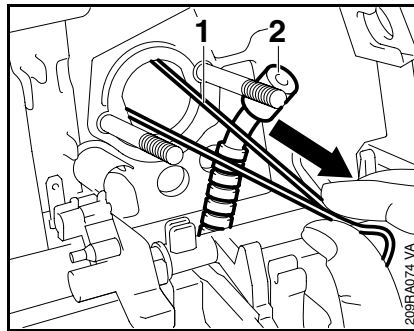

- To fit the manifold in the handle housing intake opening, wind a piece of string (about 15 cm long) around the back of the manifold flange.
- Place the handle housing in position and pass the string (1) through the housing opening.
- Pull the fuel hose (2) through the housing opening.

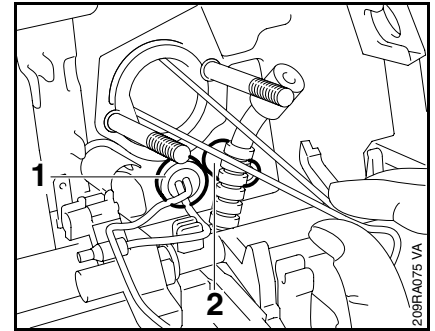

- Pass the short circuit and ground wires and grommet (1) through the housing opening.
- Fit the grommet (1).
- Pull the impulse hose (2) into the housing opening.

Pull the impulse hose into position so that its flat rear side locates against the engine housing.

Check that impulse hose and suction hose have no kinks.

Make sure the short circuit and ground wires are positioned correctly.

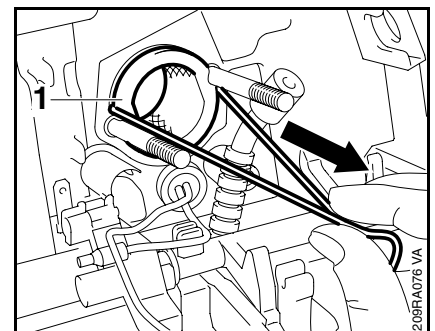

- Pull the ends of the string outward and remove the string from the manifold (1).

Install all other parts in the reverse sequence.

9.3 Annular Buffers

Rubber anti-vibration buffers are installed between the engine housing, handle housing and front handle. Damaged rubber buffers (annular buffers) must always be replaced in sets.

Apply STIHL Press Fluid OH 723,  13, to new annular buffers to simplify installation.

9.3.1 Front Handle/Handle Housing

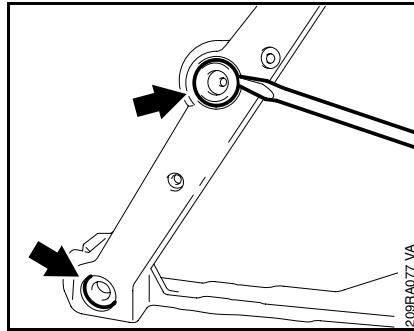

- Remove the front handle,  9.1
- Pry both annular buffers (arrows) out of the front handle.

Install in the reverse sequence.

- Coat new annular buffer with STIHL Press Fluid OH 723,  13.

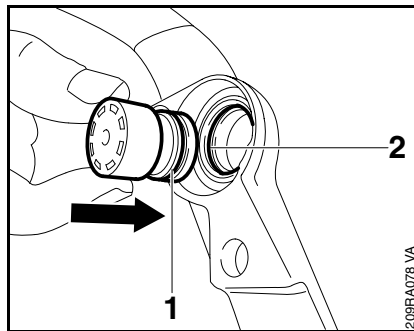



- Push the annular buffer into the front handle until its groove (1) engages over the housing rib (2).

Install all other parts in the reverse sequence.

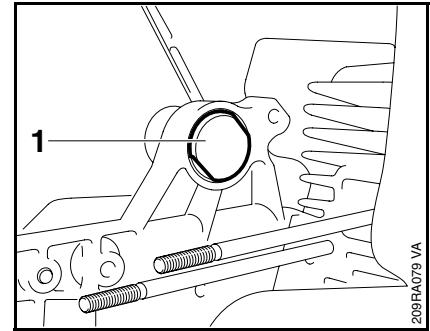
9.3.2 Handle Housing/Engine Housing



- Remove the handle housing,  9.2
- Remove the muffler if necessary,  6.1
- Pry out the plug (1).

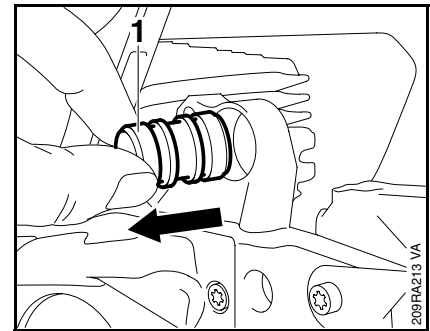

- Pry the annular buffer (1) out of the housing.

Install in the reverse sequence.

- Coat the new annular buffer with STIHL Press Fluid OH 723,  13.

9.3.3 Front Handle/Engine Housing

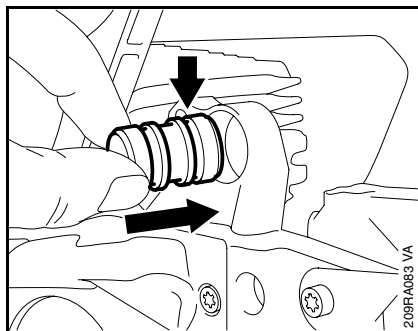

- Push annular buffer into the engine housing until its groove (arrow) engages over the housing rib.

Install all other parts in the reverse sequence.

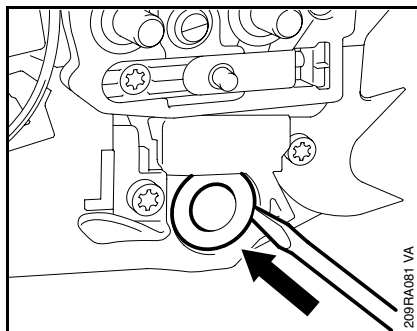

- Remove the chain sprocket cover, 5.1
- Remove the front handle, 9.1

- Push the annular buffer inwards and remove.

Install in the reverse sequence.

- Coat the new annular buffer with STIHL Press Fluid OH 723, 13.

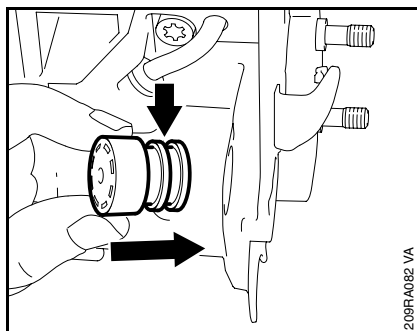

- Push the annular buffer into the engine housing from the inside so that its groove (arrow) engages over the housing rib.

Install all other parts in the reverse sequence.

9.4 Switch Shaft

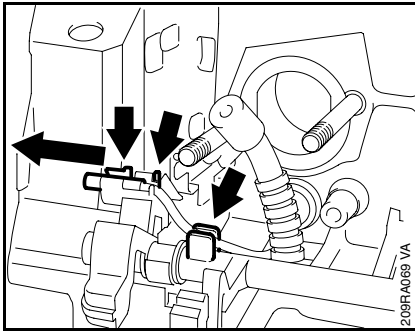

- Remove the air filter,  11.1
- Move the switch shaft to the “Choke” position.
- Pull the contact sleeve out of the switch shaft to the left.
- Pull the short circuit wire out of the retainers (arrows).

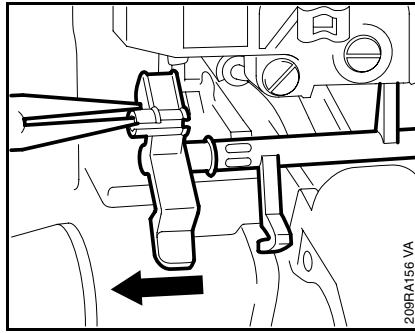

- Pull the switch shaft sideways out of the pivot mount and the handle housing.

Install in the reverse sequence.

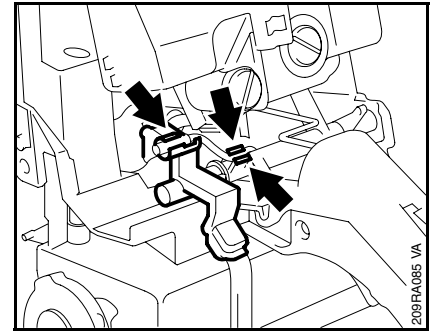

Check correct installed position of short circuit wire (arrows).

Install all other parts in the reverse sequence.

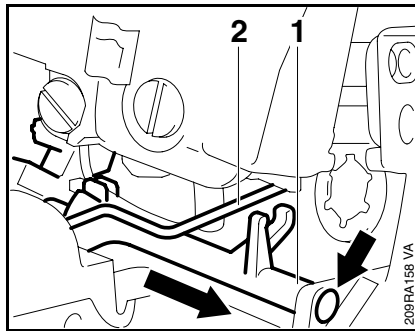

- Fit the switch shaft (1) under the throttle rod (2) and into the pivot mount (arrow).

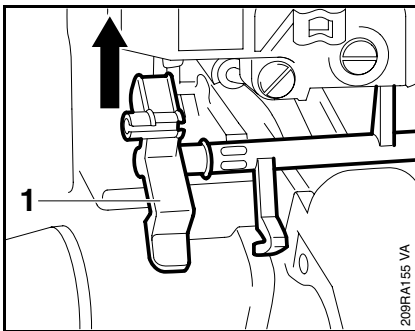

- Use a suitable tool to ease the switch shaft (1) upwards and out of the handle housing.

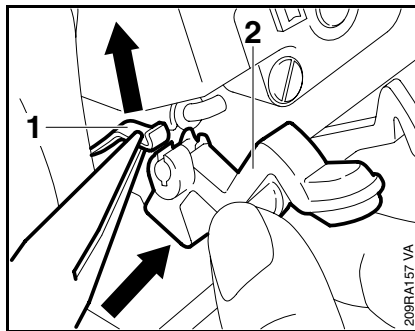

- Lift the contact spring (1) slightly to install the switch shaft (2).

9.5 Throttle Trigger/ Interlock Lever

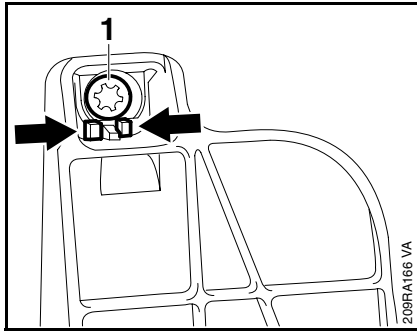

- Remove the carburetor box cover, 11.1
- Take out the screw (1).
- Squeeze the lugs (arrows) together, swing the handle molding up and lift it away.

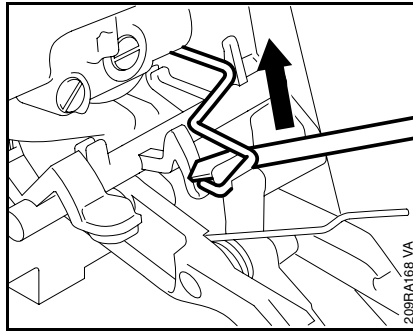

- Pry the throttle rod out of the throttle trigger.

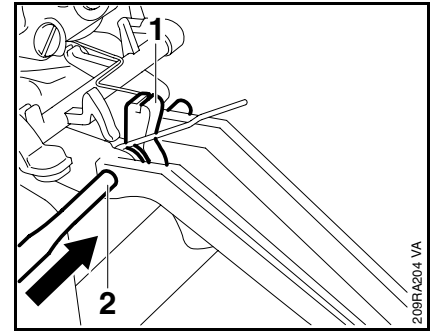

- Fit the throttle trigger (1) so that the seat for the throttle rod points upward.
- Use a 4 mm drift to push home the cylindrical pin (1).

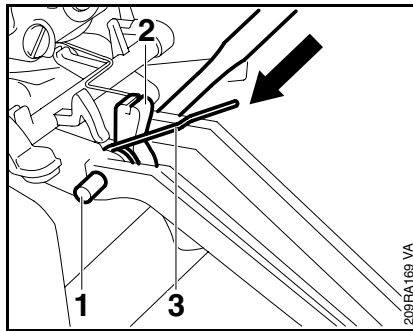

- Use a 4 mm drift to drive out the dowel pin (1).
- Take out the throttle trigger (2) with torsion spring (3).

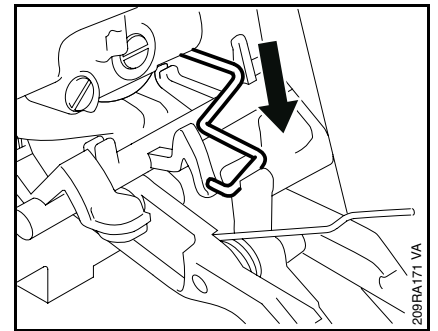

- Push the throttle rod into the throttle trigger.

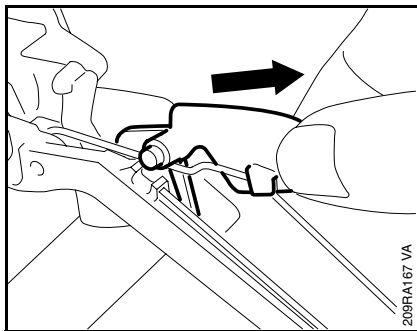

- Move switch shaft to “RUN” position.
- Take out the interlock lever.

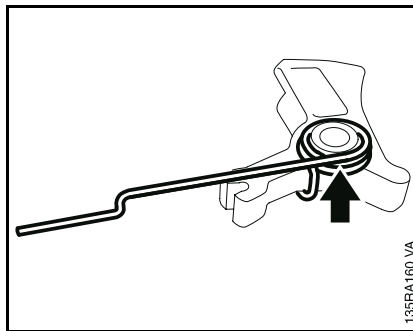

- Remove the torsion spring from the throttle trigger.

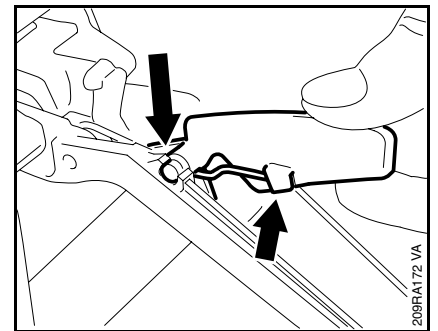

- Press the interlock lever into the slots. The torsion spring must be under the interlock lever and engage the notch.

10. Chain Lubrication

10.1 Pickup Body/Suction Hose

Impurities gradually clog the fine pores of the filter with minute particles of dirt. This prevents the oil pump from supplying sufficient oil to the bar and chain. In the event of problems with the oil supply system, first check the oil tank and the pickup body. Clean the oil tank if necessary.

– Troubleshooting –  4.3

– Unscrew the oil tank cap and drain the oil tank.

Collect chain oil in a clean container. If necessary, dispose of it properly at an approved disposal site.

– Observe safety precautions,  2.

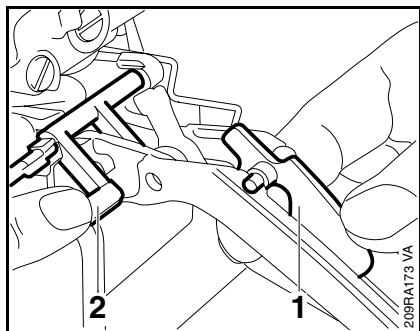

– Remove the front handle,  9.1

– Remove the clutch,  5.5

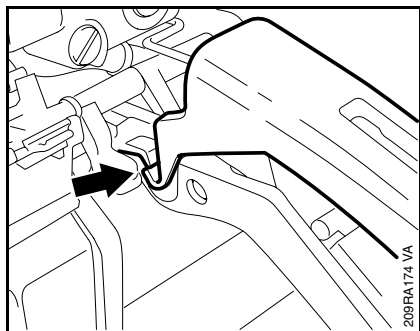

- Press the interlock lever (1) downward.
- Push the throttle trigger upward and move the switch shaft (2) to the "Choke" position.



- Fit the handle molding, making sure it engages behind the lugs as shown.
- Insert the screw and tighten it down firmly,  3.5
- Fit the carburetor box cover,  11.1

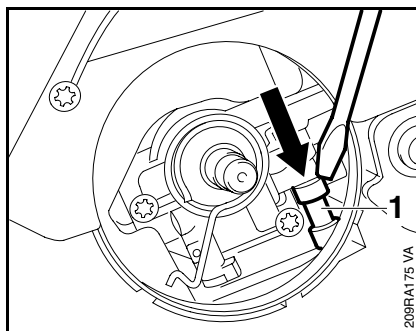

- Ease the suction hose (1) off the oil pump.

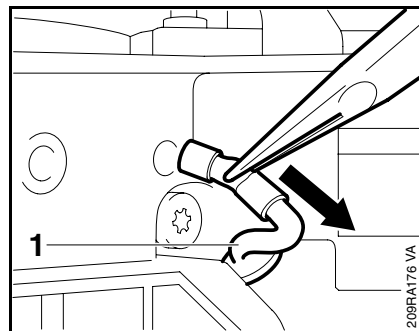

- Pull the suction hose (1) downwards and out of the engine housing.

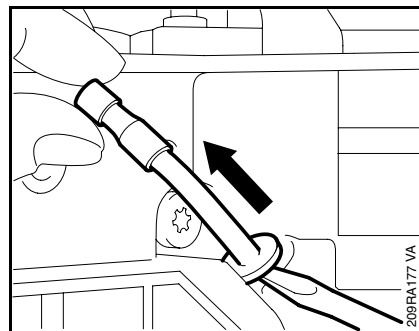

- Carefully pry the suction hose with pickup body out of the engine housing.

Take care not to damage the suction hose.

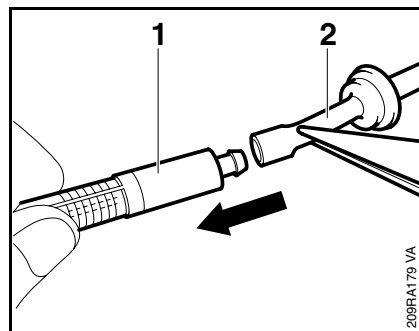

- Pull the pickup body (1) out of the suction hose (2).
- Replace the pickup body if it is damaged or very dirty.

10.2 Valve

- If necessary, flush out the oil tank.

Dispose of cleaning solution properly in accordance with local environmental requirements.

Install in the reverse sequence.

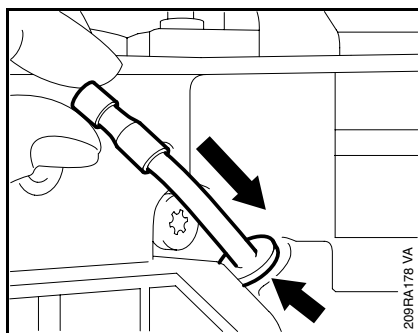

- Coat flange on suction hose with a little STIHL Press Fluid OH 723,  13.
- Carefully push the suction hose flange into the engine housing.

Install all other parts in the reverse sequence.

A valve is installed in the tank wall to keep internal tank pressure equal to atmospheric pressure.

Cleaning the valve

- Drain the oil tank.
- Remove the cutting attachment.

Collect chain oil in a clean container. If necessary, dispose of it properly at an approved disposal site.

- Observe safety precautions,  2.
- Blow the valve (1) clear with compressed air (from outside to inside of tank).
- Flush out the oil tank.

Replacing the valve

- Collect chain oil in a clean container. If necessary, dispose of it properly at an approved disposal site.

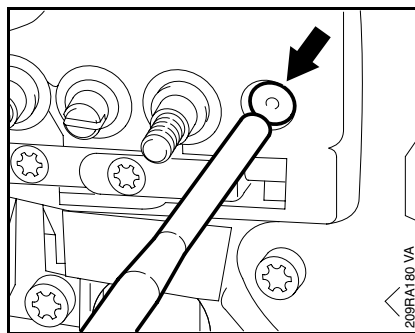

- Use a 7 mm drift the carefully drive the valve out of its seat and into the engine housing.
- Remove the faulty valve from inside the tank.

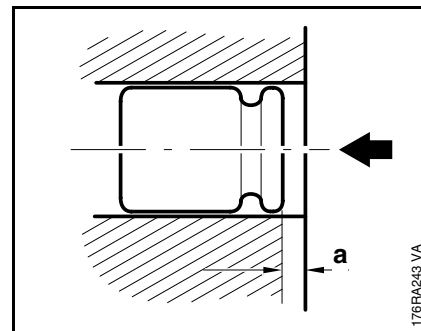

- Use a 7 mm drift to carefully press home the new valve until it is about 1 mm below the housing face ('a' in illustration).

Reassemble all other parts in the reverse sequence.

10.3 Tank Cap

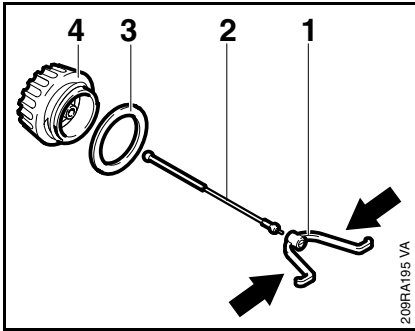

– Drain the oil tank.

Collect chain oil in a clean container. If necessary, dispose of it properly at an approved disposal site.

Machines up to 1998

- Carefully squeeze the hook (1) and pull it out of the engine housing.
- Remove the sealing ring (3).
- Take cord (2) off the tank cap (4).

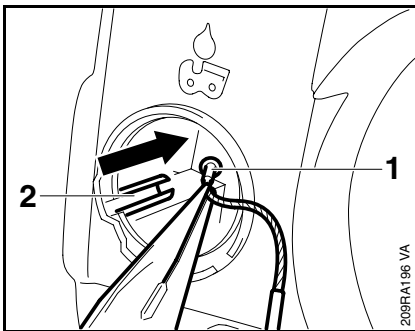

Machines from 1998

- Carefully disconnect nipple (1) of cap retainer from the guide (2) in the engine housing.

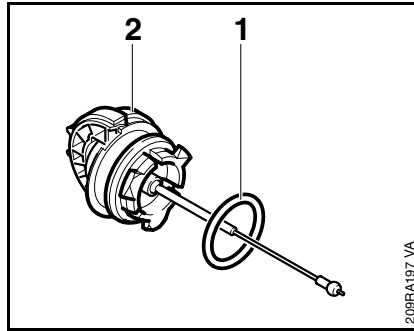

- Remove the sealing ring (1) from the tank cap (2).

Install in the reverse sequence.

Always install a new sealing ring.

10.4 Oil Pump

10.4.1 Removing and Installing

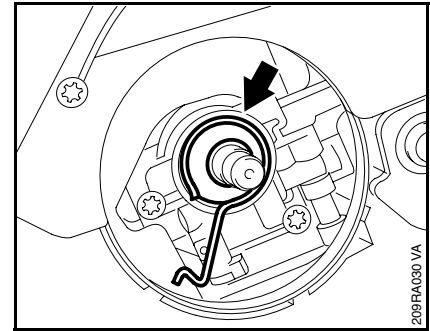

- Remove the clutch,  5.5
- Remove the worm with drive spring (arrow).

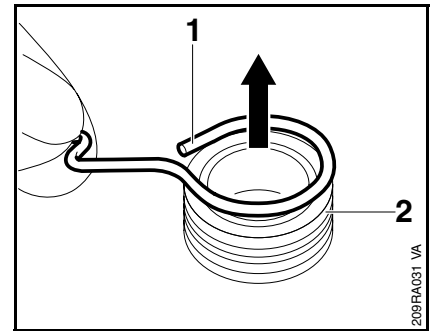

- Take the drive spring (1) off the worm (2).

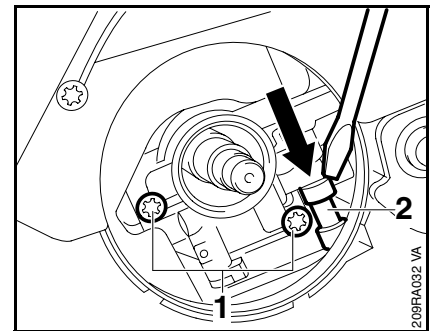

- Use a suitable tool to push the hose (2) down and off the pump.
- Take out the screws (1).

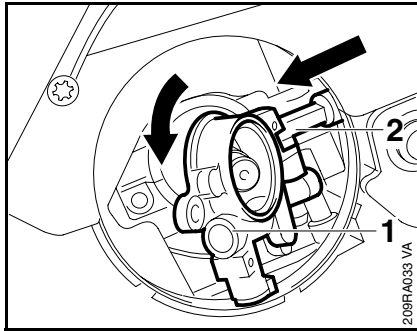

- Swing the oil pump (1) forwards a little.
- Carefully remove oil pump (1), pulling the elbow connector (2) off the engine housing nipple at the same time.
- Remove the muffler, 6.1

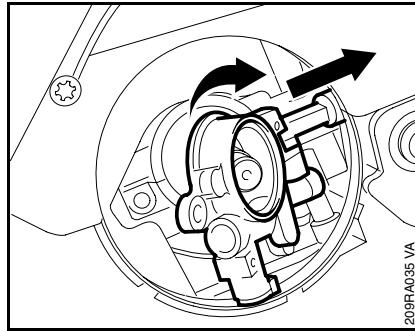

- Hold the elbow connector at a slight angle and fit the oil pump.

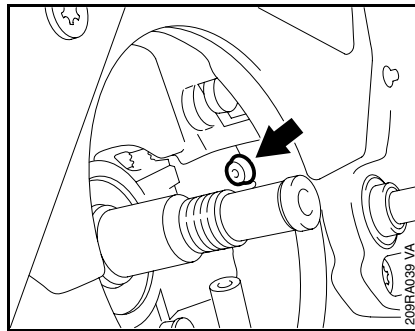

- Push the elbow connector onto the engine housing nipple (arrow).

The elbow connector must snap audibly into position.

- Line up the oil pump.

Install all other parts in the reverse sequence.

When fitting the cover washer, make sure the word “TOP” faces outwards.

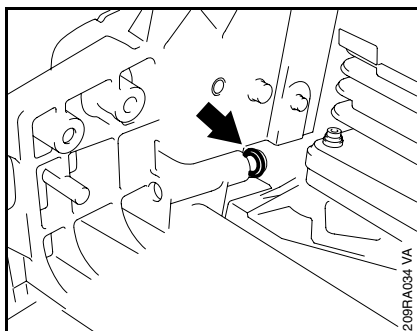

- Fit new O-ring (arrow) on engine housing nipple.

Install in the reverse sequence.

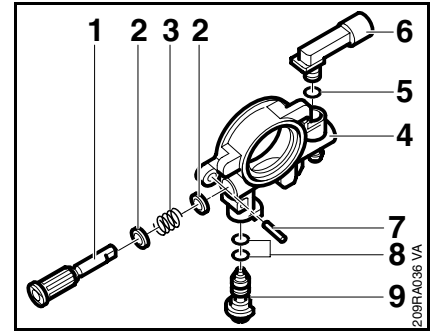

Check the suction hose and pickup body are clean before dis-assembling the oil pump, 10.1.

- Remove the oil pump, 10.4.1

- Turn the elbow connector (6) forwards through 90 degrees and pull it out of the oil pump (4).
- Take the O-ring (5) off the elbow connector.
- Use a 2 mm drift to drive out the spring pin (7).
- Pull the control bolt (9) out of the housing and remove the O-rings (8).
- Remove the pump piston (1) with spring (3) and washers (2).

- Clean all parts with standard solvent-based degreasant containing no chlorinated or halogenated hydrocarbons, 13.

Install in the reverse sequence.

11. Fuel System

11.1 Air Filter

Dirty air filters reduce engine power, increase fuel consumption and make starting more difficult.

The air filter should be cleaned when there is a noticeable loss of engine power.

- Close the choke shutter.

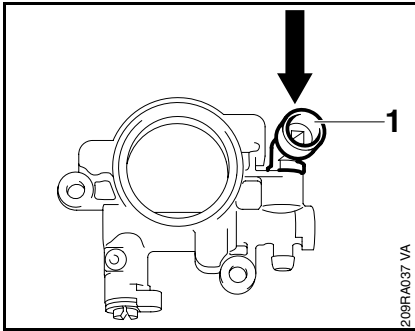

- Hold the elbow connector (1) at 90 degrees and push it into the pump.
- Turn the elbow connector to the right.

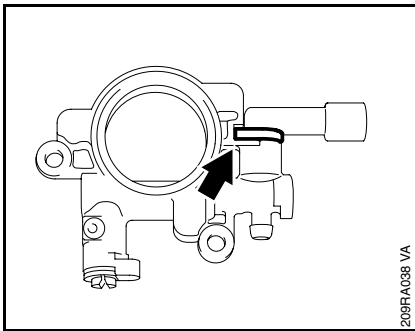

- Make sure the guide lug on the elbow connector engages the recess in the oil pump.

Always install new O-rings.

- Lubricate the pump piston and worm with grease before installing, 13.

Install all other parts in the reverse sequence.

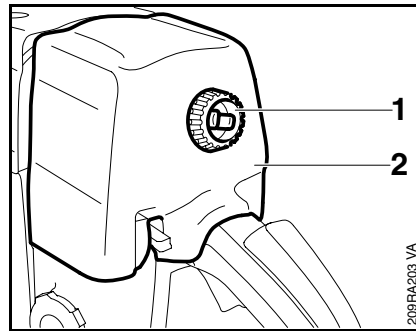

Machines up to 2002

- Turn the twist lock (1) 90 degrees to the left (counterclockwise)
- Remove the carburetor box cover to the rear.

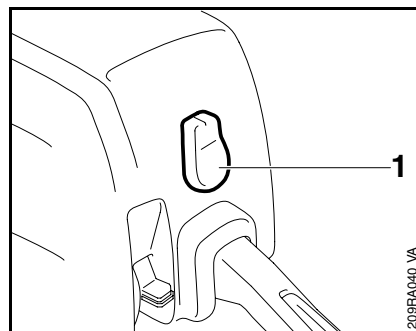

Machines from 2002

- Turn the twist lock (1) 90 degrees to the left (counterclockwise).
- Remove the carburetor box cover to the rear.

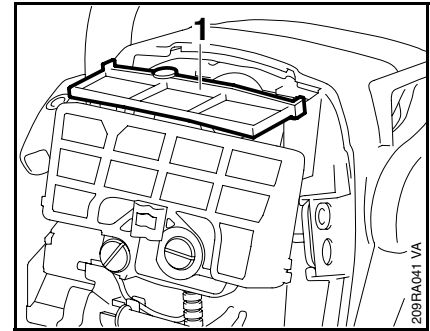

- Remove all loose dirt from around the filter.
- Remove the prefilter (1) upwards.

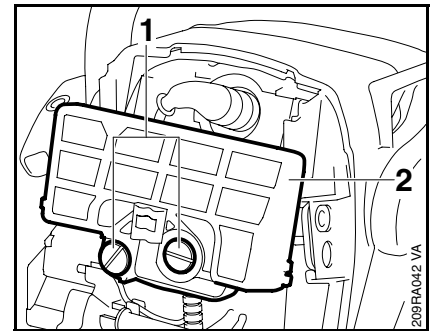

- Unscrew the slotted nuts (1).
- Remove the air filter (2).

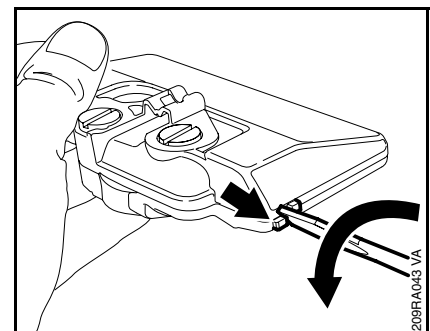

- Insert blade of screwdriver between the lugs.

11.2 Carburetor

11.2.1 Removing and Installing

- Turn the screwdriver counterclockwise to pry the two halves of the air filter apart.
- Repeat the procedure on the other side.

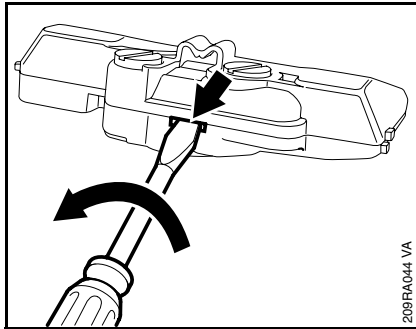

- Insert blade of screwdriver in the slot (arrow) and turn it to separate the two halves of the air filter.

Knock out the filter or blow the two halves clear with compressed air from the inside outwards.

- Wash filter parts in a little standard solvent-based degreasant containing no chlorinated or halogenated hydrocarbons.

Do not clean fleece filters with a brush.

Replace damaged air filter elements.

Install in the reverse sequence.

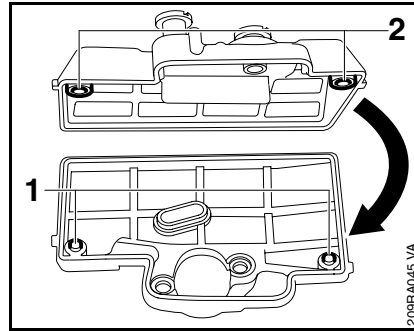

- Detents (1) must engage audibly in the bushings (2).

Install all other parts in the reverse sequence.

Make sure compensator connection is properly seated.

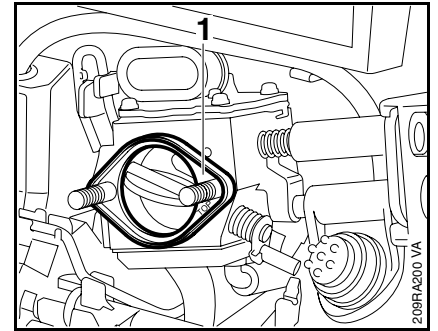

- Remove the air filter, 11.1
- Remove the baffle (1) (if fitted).

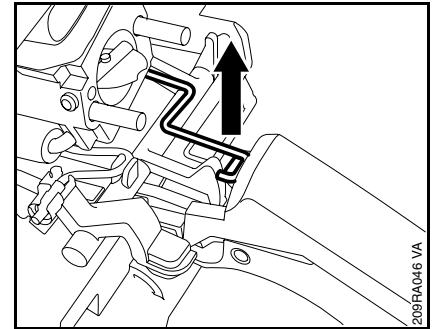

- Open the throttle wide.
- Disconnect the throttle rod from the throttle trigger.

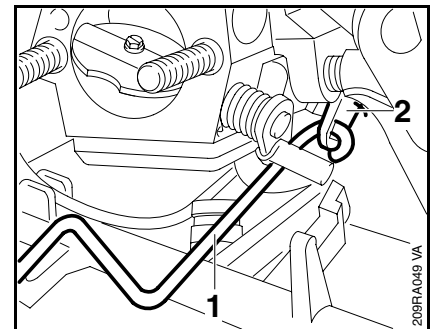

- Disconnect the throttle rod (1) from the throttle shaft (2).

11.2.2 Leakage Test

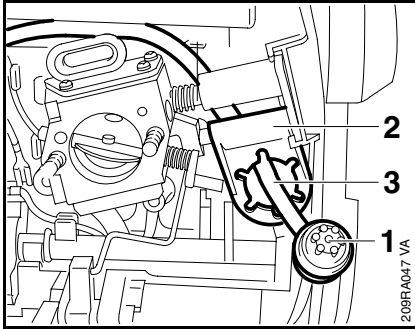

- Pull the tank vent (1) (if fitted) out of the grommet (2).
- Pull the hose (3) off the tank vent (1).

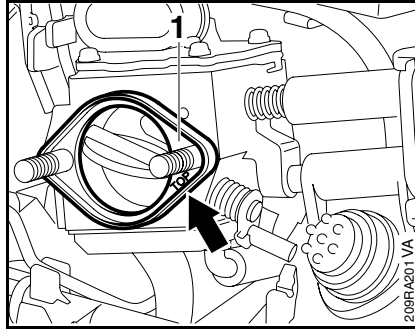

- Where applicable, fit baffle(1) with the word "TOP" (arrow) facing outwards.

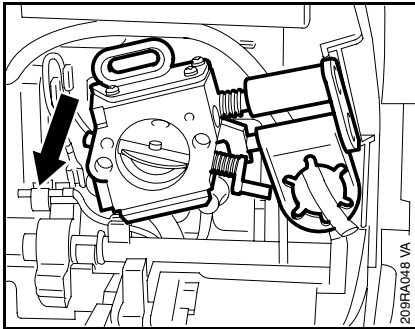

- Remove the carburetor with grommet.
- Pull the grommet off the carburetor.

Install in the reverse sequence.

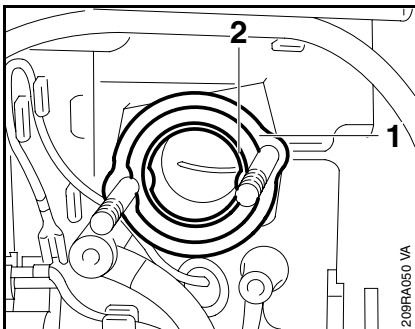

- Check that the washer (1) and sleeve (2) are in place and correctly seated.

Install all other parts in the reverse sequence.

– Troubleshooting – 4.5

In the case of problems with the carburetor or fuel supply system, also check and clean,  11.5.1 and 11.5.2.

The carburetor can be tested for leaks with the carburetor and crankcase tester 1106 850 2905.

- Remove the carburetor,  11.2.1

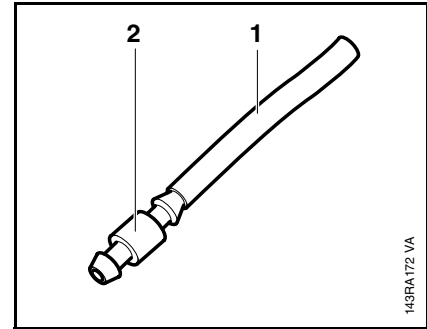

- Push the fuel line (1) 1110 141 8600 onto the nipple (2) 0000 855 9200.

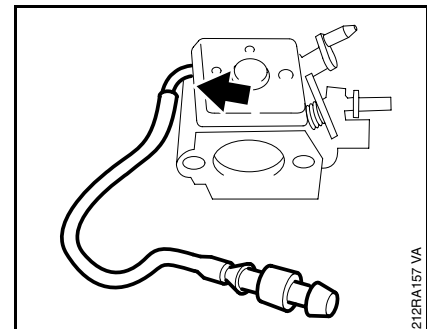

- Push the fuel line with nipple onto the carburetor's elbow connector.

11.3 Servicing the Carburetor

11.3.1 Metering Diaphragm

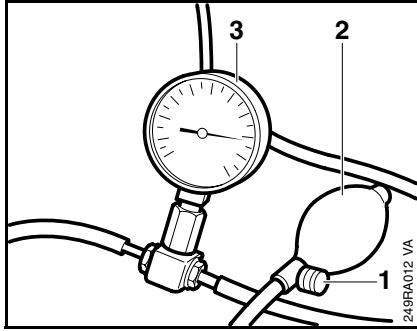

- Push the nipple into the pressure hose of tester 1106 850 2905.
- Close the vent screw (1) on the rubber bulb (2) and pump air into the carburetor until the pressure gauge (3) shows a reading of approx. 0.8 bar (80 kPa).

If this pressure remains constant, the carburetor is airtight. However, if it drops, there are two possible causes:

1. The inlet needle is not sealing (foreign matter in valve seat or sealing cone of inlet needle is damaged or inlet control lever sticking). Remove to clean, 11.3.2

2. Metering diaphragm damaged, replace if necessary, 11.3.1

– After completing the test, open the vent screw (1) and pull the fuel line off the carburetor.

– Push the fuel hose onto the elbow connector.

– Install the carburetor, 11.2.1

Reassemble all other parts in the reverse sequence.

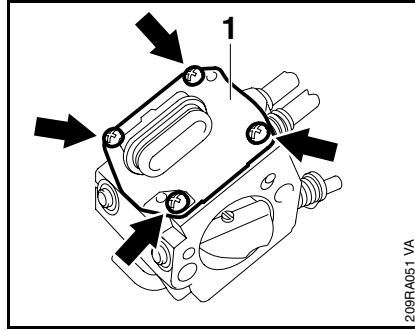

– Remove the carburetor, 11.2.1

Carburetor without limiter caps

- Take out the screws (arrows).
- Remove the end cover (1).

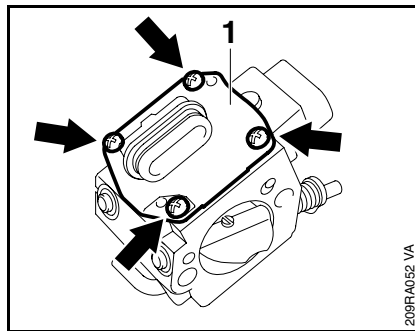

Carburetor with limiter caps

- Take out the screws (arrows).
- Remove the end cover (1).

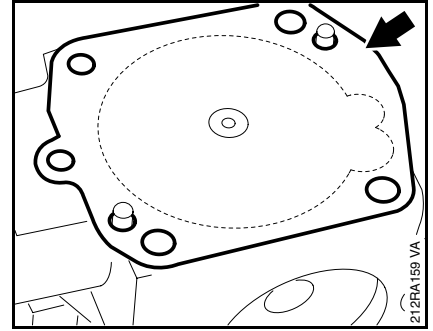

- Remove the metering diaphragm and gasket (arrow) from the carburetor body or end cover.

If the gasket and diaphragm are stuck to the carburetor, remove them very carefully.

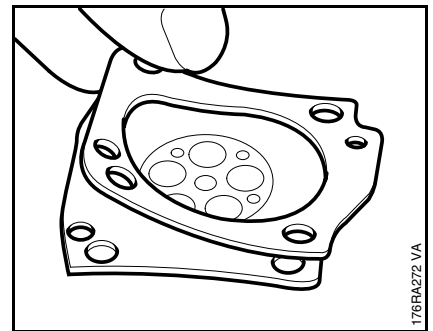

- Carefully separate the diaphragm and gasket.

11.3.2 Inlet Needle

The diaphragm material as well as the inlet and outlet valves are subjected to continuous alternating stresses and eventually show signs of fatigue, i.e. the diaphragm distorts and swells and has to be replaced.

Install in the reverse sequence.

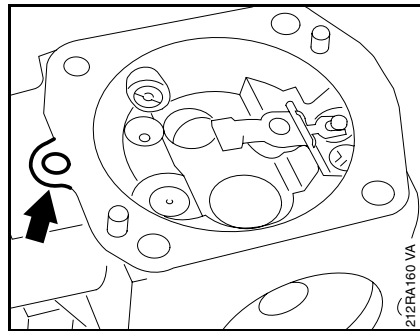

- Place the gasket on the carburetor body so that the tab (arrow) points towards the adjusting screws.

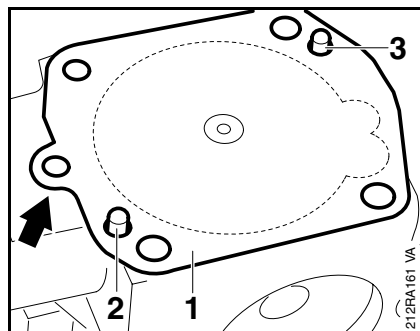



- Fit the metering diaphragm (1) on the carburetor body so that the perforated plate faces the inlet control lever and the tab (arrow) points towards the adjusting screws.

The gasket and metering diaphragm are held in position by integrally cast pegs (2+3).

- Fit the end cover.
- Fit screws and tighten them down firmly,  3.5

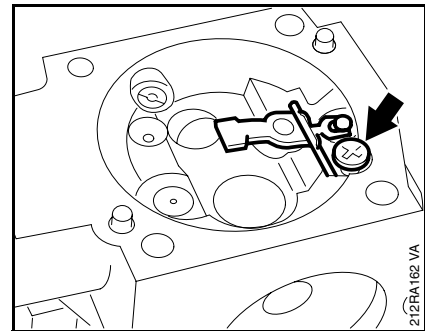
Install all other parts in the reverse sequence.



- Remove the metering diaphragm,  11.3.1
- Take out the screw (arrow).
- Remove the inlet control lever with spindle.

There is a small spring under the inlet control lever which may pop out during disassembly.

- Take out the inlet needle.

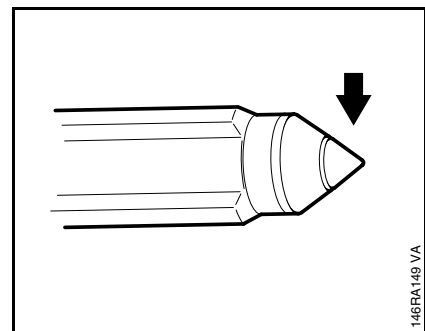

- If there is an annular indentation on the sealing cone of the inlet needle, fit a new inlet needle.

11.3.3 Fixed Jet

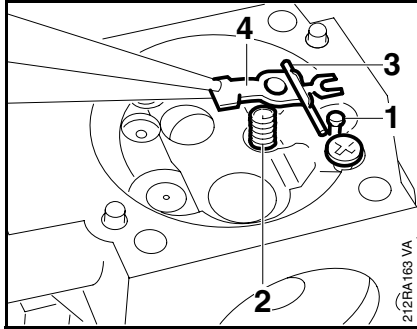

Install in the reverse sequence.

- Fit the inlet needle (1).
- Fit spring (2) in bore.
- Insert spindle (3) in the inlet control lever (4).
- Engage clevis in annular groove on head of the inlet needle.
- Press the inlet control lever down and secure it with the screw.

Make sure the helical spring locates on the control lever's nipple.

- Check that inlet control lever moves freely.

The upper face of the inlet control lever must be flush with the top of the carburetor body.

- Install the metering diaphragm,  11.3.1

Install all other parts in the reverse sequence.

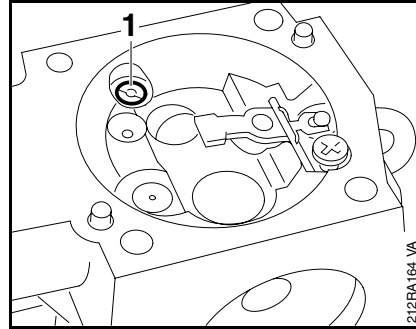



- Remove the metering diaphragm,  11.3.1
- Use a suitable screwdriver to unscrew the fixed jet (1).

Take care not to damage the fixed jet.

Install in the reverse sequence.

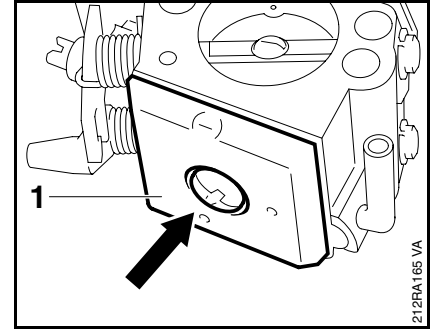
11.3.4 Pump Diaphragm



- Remove the carburetor,  11.2.1
- Take out the screw (arrow).
- Remove the end cover (1).

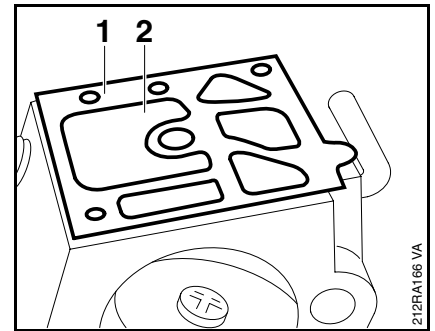

- Carefully remove the gasket (1) and pump diaphragm (2) from the end cover or carburetor body.

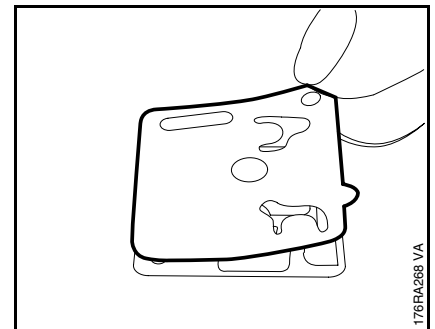

- Carefully separate the diaphragm and gasket.
- Inspect diaphragm for damage and wear, fit a new gasket.

The diaphragm material as well as the inlet and outlet valves are subjected to continuous alternating stresses and eventually show signs of fatigue, i.e. the diaphragm distorts and swells and has to be replaced.

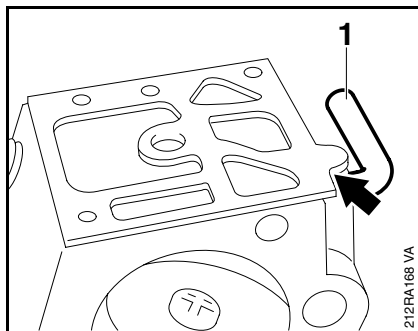

- Fit the diaphragm and gasket on the carburetor body so that the tabs (arrow) point toward the connector (1).

– Place the end cover on the carburetor body.

The pump diaphragm, gasket and end cover are held in position by integrally cast pegs.

- Fit the screw and tighten it down firmly,  3.5

Install all other parts in the reverse sequence.

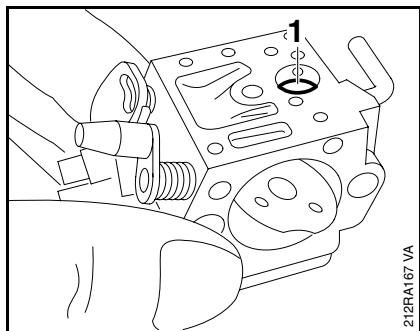

- Check fuel strainer (1) for contamination and damage. If necessary, use a needle to take it out of the carburetor and clean or replace.

Install in the reverse sequence.

11.4 Adjusting Carburetor

11.4.1 User Adjustment (Carburetor without Limiter Caps)

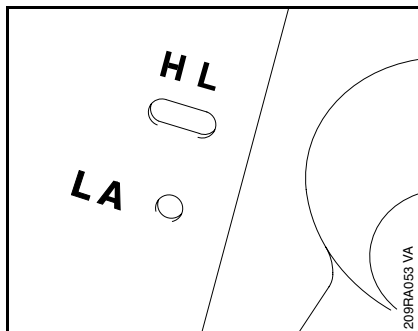

Standard setting (without tachometer)

To readjust the carburetor, start with the standard setting.

- Carefully screw down both adjusting screws (H and L) until they are against their seats.

Then make the following adjustments:

- Open high speed screw (H) one full turn.
- Open low speed screw (L) one full turn.

If no tachometer is available, do not turn the high speed screw (H) beyond the standard setting to make the mixture leaner.

Standard setting (with tachometer)

- Check the air filter and clean or replace as necessary.
- Check and clean or replace spark arresting screen (if fitted).
- Check chain tension.
- Warm up the engine.
- Adjust idle speed.

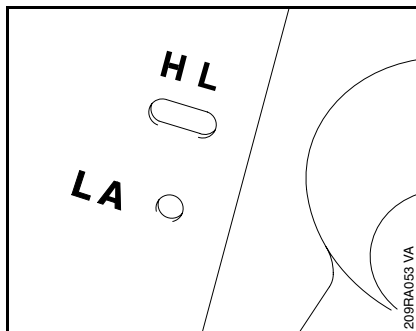

Adjusting idle speed

- Adjust idle speed with a tachometer. Adjust specified engine speeds within tolerance of +/- 200 rpm.

1. Adjust engine speed with idle speed screw (LA) to 3,300 rpm.
2. Turn low speed screw (L) clockwise or counterclockwise to obtain maximum engine speed.

If this speed is higher than 3,700 rpm, abort the procedure and start again with step 1.

3. Use the idle speed screw (LA) to set engine speed again to 3,300 rpm.
4. Set the engine speed to 2,800 rpm with the low speed screw (L).

Starting from the standard setting, use the high speed screw (H) to adjust the maximum engine speed to:

- 12,500 rpm (**MS 290**)
- 13,000 rpm (**MS 310, 390**)

If the setting is **too lean** there is a risk of engine damage due to insufficient lubrication and overheating.

Engine stops while idling

- Turn the idle speed screw **LA** clockwise until the chain begins to run – then turn the screw back one quarter of a turn.

Chain runs when engine is idling

- Turn the idle speed screw **LA** counterclockwise until the chain stops running – then turn the screw another quarter turn in the same direction.

Erratic idling behavior, poor acceleration

- Idle setting too lean. Turn the low speed screw **L** counterclockwise until the engine speed drops – then turn the screw back one quarter of a turn.

11.4.2 User Adjustment (Carburetor with Limiter Caps)

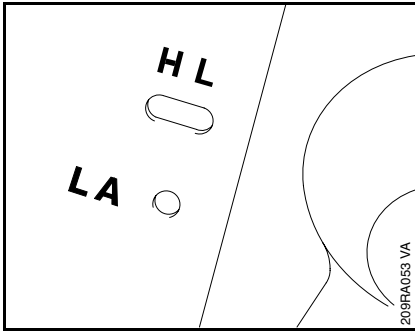

Standard setting

Do not remove the limiter cap to carry out the standard setting.

- With this carburetor it is only possible to correct the settings of the high speed screw (H) and low speed screw (L) within fine limits

Make the following adjustments:

- Close high speed screw (H) by turning it clockwise as far as stop, then open it 3/4 turn counterclockwise.
- Close the low speed screw (L) by turning it clockwise as far as stop, then open it 1/4 turn counterclockwise.

Adjusting idle speed

Engine stops while idling

- Open the low speed screw **L** one quarter of a turn.
- Turn the idle speed screw **LA** clockwise until the chain begins to run – then turn the screw back one quarter of a turn.

Chain runs when engine is idling

- Open the low speed screw **L** one quarter of a turn.
- Open the idle speed screw **LA** counterclockwise until the chain stops running – then turn the screw another full turn in the same direction.

Erratic idling behavior, poor acceleration

Irregular idling or poor acceleration even though the low speed screw is set to one quarter turn open.

- Idle setting too lean. Turn the low speed screw **L** counterclockwise, but no further than stop, until the engine runs and accelerates smoothly.
- It is usually necessary to change the setting of the idle speed screw **LA** after every correction to the low speed screw **L**.

Adjustment for operation at high altitude or at sea level

A slight correction of the setting may be necessary if engine power is not satisfactory when operating at high altitude or at sea level.

- Check the standard setting.
- Warm up the engine.

At high altitude (mountains)

- Turn the high speed screw **H** clockwise (leaner), no further than stop.

At sea level

- Turn the high speed screw **H** counterclockwise (richer), no further than stop.

If the setting is **too lean** there is a risk of engine damage due to insufficient lubrication and overheating.

11.4.3 Basic Setting (Carburetor with Limiter Caps)

The limiter caps need to be removed from the adjusting screws only if it is necessary to replace the high speed screw (H) or low speed screw (L) or clean the carburetor.

Carry out the two following steps:

After removing the limiter cap it is necessary to carry out the basic setting.

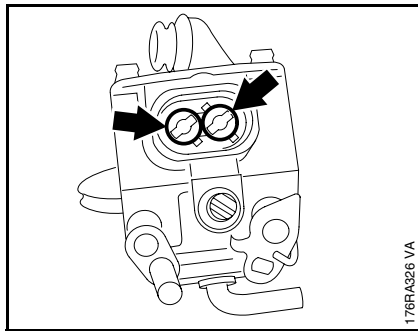

- Turn the limiter caps (arrows) of the H and L screws counterclockwise as far as stop so that the lugs of the limiter caps line up with the carburetor openings.

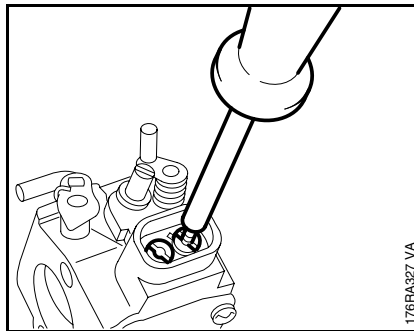

- Insert puller 5910 890 4500 in center of limiter caps, apply slight pressure and screw home counterclockwise until the limiter caps come out of the carburetor body.

After removing the limiter caps, first carry out the basic setting.

- Screw both adjusting screws down onto their seats.

Make the following adjustments:

- Open the high speed screw (H) one full turn clockwise.
- Open the low speed screw (L) one full turn clockwise.
- Set the engine speed to 2,800 rpm with the low speed screw (L).
- If no tachometer is available, mount the limiter caps, see step 6

Fine tuning (with tachometer)

- Check the air filter and clean or replace as necessary.
- Check and clean or replace spark arresting screen (if fitted).

- Check chain tension.
- Warm up the engine.

Adjust engine idle speed with a tachometer. Adjust specified engine speeds to within a tolerance of +/- 200 rpm.

1. Adjust engine speed with idle speed screw (LA) to 3,300 rpm.
2. Turn low speed screw (L) clockwise or counterclockwise to obtain maximum engine speed.

If this speed is higher than 3,700 rpm, abort the procedure and start again with step 1.

3. Use the idle speed screw (LA) to set engine speed again to 3,300 rpm.
4. Set the engine speed to 2,800 rpm with the low speed screw (L).
5. Use the high speed screw (H) to adjust the maximum engine speed to:
12,500 rpm (MS 290)
13,000 rpm (MS 310 and MS390)
6. Install new limiter caps, noting that the stop lugs on the limiter caps must line up with the openings in the carburetor.

Always install new limiter caps. Limiter caps that have been removed once may be damaged and must not be re-used.

Correct operation of the carburetor is only possible if atmospheric pressure and internal fuel tank pressure are equal at all times. This is ensured by the tank vent.

In the event of trouble with the carburetor or the fuel supply system, always check and clean the tank vent.

Check operation by performing vacuum test on the tank via the fuel hose.

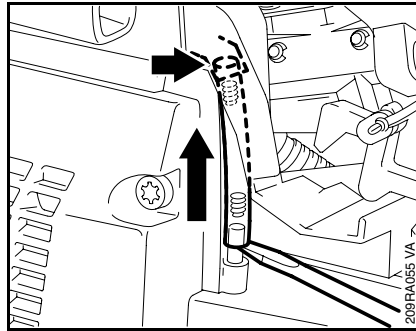

- Remove the carburetor box cover, 11.1
- Use a suitable tool to pry the tank vent off the nipple on the fuel tank.
- Take the tank vent out of its seat in the handle housing (arrow).

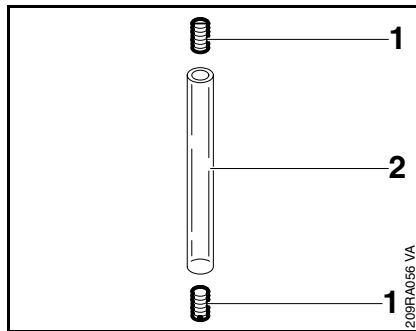

- Use a 3 mm drift to push the grub screws (1) out of the vent hose (2).

Clean all components in standard solvent-based degreasant containing no chlorinated or halogenated hydrocarbons, 13.

Install in the reverse sequence.

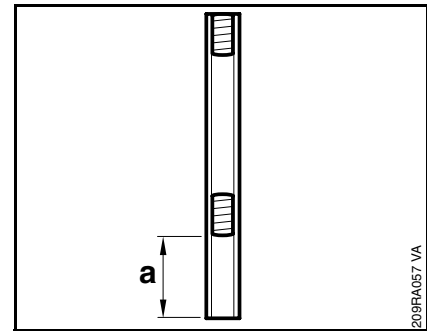

- Use a 3 mm drift to push the grub screws (1) into the vent hose (2).

Pay special attention to correct installed position of lower grub screw. Dimension 'a' should be about 18 mm.

Check correct installed position of tank vent in the handle housing.

Install all other parts in the reverse sequence.

11.5.2 Machines from 2002

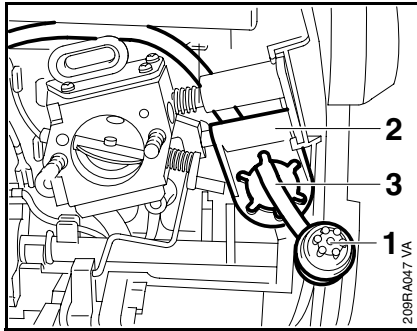

- Drain the fuel tank.
- Clean loose dirt from the air filter and the area around it.
- Remove the air filter, 11.1
- Pull tank vent valve (1) out of the retainer (2) and off the hose (3).

- Use vacuum pump to subject tank vent valve to vacuum.

Equalization of pressure in the fuel tank takes place via the tank vent valve. There must be no build-up of vacuum during the test. In the event of a malfunction, install a new tank vent.

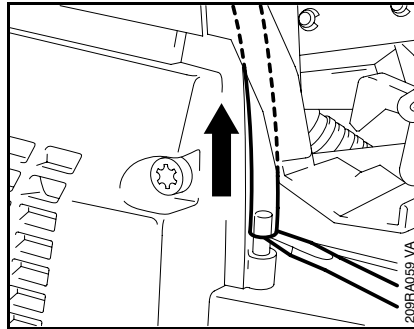

- Pry the hose off the engine housing nipple.

- Remove the hose.

Clean the hose with compressed air and a little standard solvent-based degreasant containing no chlorinated or halogenated hydrocarbons, 13.

Inspect components for damage and cracks and replace if necessary.

Install in the reverse sequence.

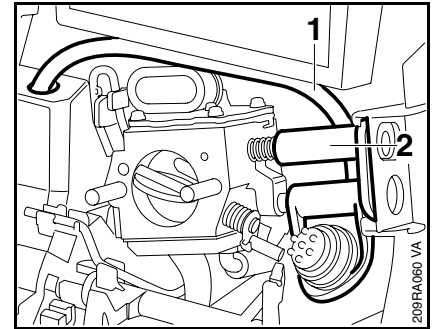

- Position the hose (1) behind the grommet (2).

Fit the tank vent in the grommet so that its stub points upwards.

Make sure the hoses are not kinked.

Install all other parts in the reverse sequence.

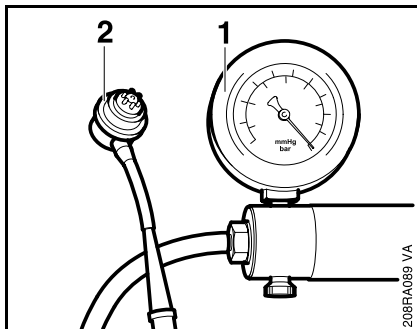

- Connect vacuum pump 0000 850 3501 (1) with hose to tank vent (2).

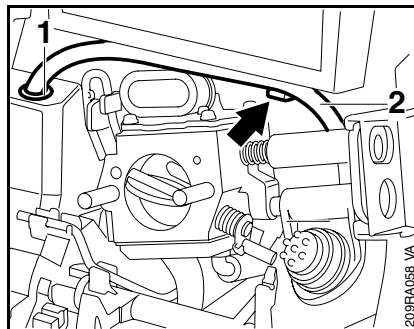

- Pry the grommet (1) out of the handle housing.
- Take the hose (2) out of the retainer (arrow).

11.6 Fuel Tank

11.6.1 Pickup Body

The diaphragm pump draws fuel out of the tank and into the carburetor via the fuel hose. Any impurities mixed with the fuel are retained by the pickup body (filter). The fine pores of the filter eventually become clogged with minute particles of dirt. This restricts the passage of fuel and results in fuel starvation.

In the event of trouble with the fuel supply system, always check the fuel tank and the pickup body first. Clean the fuel tank if necessary.

In the event of trouble with the fuel supply system, always check the fuel tank and the pickup body first. Clean the fuel tank if necessary.

Cleaning the fuel tank

- Remove the fuel tank cap and drain the tank.
- Pour a small amount of clean gasoline into the tank. Close the tank and shake the saw vigorously.
- Open the tank again and drain it.

Dispose of fuel properly in accordance with environmental requirements.

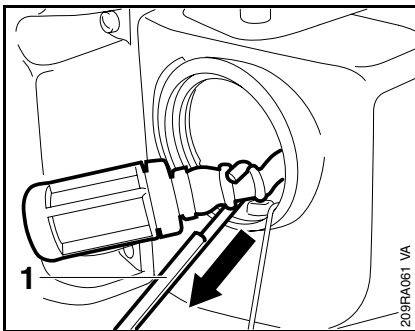

- Use hook (1) 5910 893 8800 to pull the pickup body out of the fuel tank.

Do not stretch the suction hose.

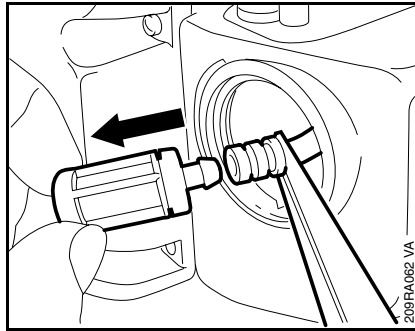

- Pull the pickup body off the suction hose.
 - Fit a new pickup body.
- Install in the reverse sequence.

11.6.2 Suction Hose

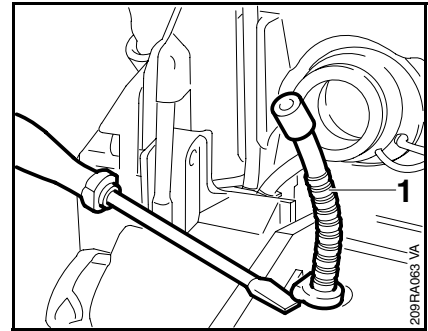

- Remove the handle housing, 9.2
- Remove the pickup body, 11.6.1
- Pry fuel hose (1) flange out of the fuel tank.
- Pull out the hose (1).

Install in the reverse sequence.

- Coat the hose flange with a little oil.

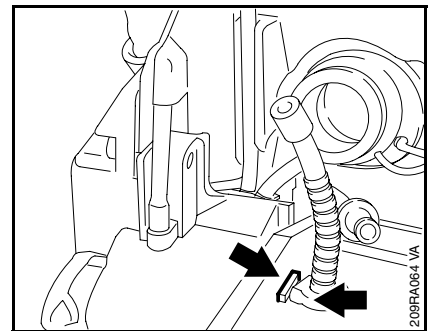

- Straight side of flange must be in line with the rib.

Install all other parts in the reverse sequence.

11.6.3 Tank Cap

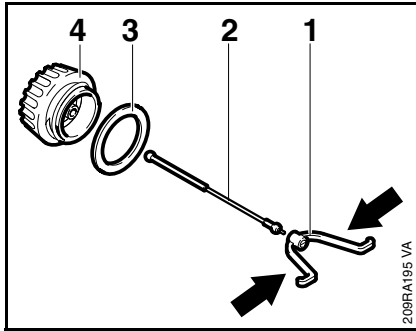

- Drain the fuel tank.

Collect fuel in a clean container. If necessary, dispose of it properly at an approved disposal site.

Machines up to 1998

- Carefully squeeze the hook (1) and pull it out of the engine housing.
- Remove the sealing ring (3).
- Take cord (2) off the tank cap (4).

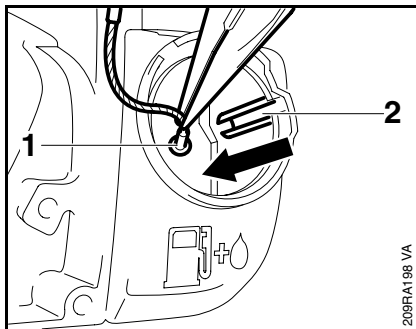

Machines from 1998

- Carefully disconnect nipple (1) of cap retainer from the guide (2) in the engine housing.

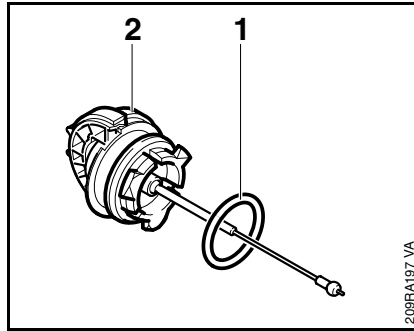

- Remove the sealing ring (1) from the tank cap (2).

Install in the reverse sequence.

Always install a new sealing ring.

11.6.4 Replacing Engine Housing

The fuel tank and engine housing are a single unit.

- Drain off oil and fuel and collect in a clean container. If necessary, dispose of properly at an approved disposal site.
- Remove the spiked bumper, 5.3
- Remove the chain brake, 5.6.2
- Remove the handle housing, 9.2
- Remove the fuel suction hose, 11.6.2
- Remove the oil suction hose, 10.1

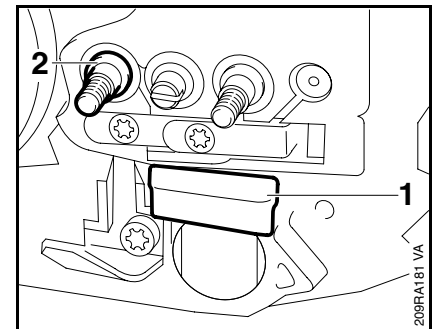

- Pry the bumper strip (1) out of the housing.
- Use stud puller 5910 893 0501 to remove the collar stud (2).

- Remove the chain catcher,
📖 5.2
- Remove the annular buffers from
the front handle/engine housing,
📖 9.3.2
- Remove the annular buffer from
the handle housing/engine
housing, 📖 9.3.3
- Remove the chain tensioner,
📖 5.8
- Remove the wiring harness,
📖 7.5
- Remove engine with engine pan,
📖 6.5
- Remove the tank caps,
📖 10.3 and 📖 11.6.3

Install in the reverse sequence.

12. Special Servicing Tools

No.	Part Name	Part No.	Application	Rem.
1	Locking strip	0000 893 5903	Blocking the crankshaft	
2	Sealing plate	0000 855 8106	Sealing exhaust port	
3	Wooden assembly block	1108 893 4800	Fitting piston	
4	Clamping strap	1127 893 2601	Compressing piston rings	
5	Test flange	1128 850 4200	Leakage test	
6	Hook	5910 890 2800	Detaching clutch springs	
7	Carburetor and crankcase tester	1106 850 2905	Testing crankcase and carburetor for leaks	
8	Vacuum pump	0000 850 3501	Testing crankcase for leaks, checking tank vent	
9	- Nipple	0000 855 9200	Testing carburetor for leaks	
10	- Fuel line	1110 141 8600	Testing carburetor for leaks	
11	Press sleeve	1122 893 4600	Installing oil seal	
12	Puller	5910 890 4400	Removing oil seals	
13	- Jaws (No. 3.1 + 4)	0000 893 3706	Removing oil seal(s)	
14	Sleeve	1127 851 8300		
15	Press sleeve	1127 893 2400	Installing oil seals	
16	Assembly drift	1110 893 4700	Removing and installing piston pin	
17	Ignition system tester ZAT 4	5910 850 4503		
18	Ignition system tester ZAT 3	5910 850 4520		
19	Installing tool 12	5910 890 2212	Fitting hookless snap rings in piston	
20	Stud puller M8	5910 893 0501	Removing bar mounting studs	
21	Installing tool	1116 893 4800	Rewinding the rewind spring	
22	Setting gauge	1111 890 6400	Setting air gap between ignition module and flywheel	
23	Hook	5910 893 8800	Removing pickup body	
24	Assembly stand	5910 890 3100	Holding saw for servicing/repairs	
25	Puller	1116 893 0800	Removing flywheel	
26	Assembly tube	1117 890 0900	Detaching and attaching brake spring	
27	Installing tool	0000 890 2201	Flaring rope guide bushing	
28	Torque wrench	5910 890 0301	0.5 to 18 Nm Alternative: Torque wrench 5910 890 0302 with optical/acoustic signal	
29	Torque wrench	5910 890 0311	6 to 80 Nm Alternative: Torque wrench 5910 890 0312 with optical/acoustic signal	

No.	Part Name	Part No.	Application	Rem.
30	Crimping tool	5910 890 8210	Attaching connectors to electrical wires	
31	Puller	5910 890 4500	Removing limiter cap	
32	Socket, 13 mm, DIN 3124	5910 893 5608	Flywheel nut	
33	Socket, 19 mm, DIN 3124	5910 893 5613	Clutch	
34	Screwdriver bit T 27 x 125	0812 542 2104	Removing and installing spline socket head screws with electric or pneumatic screwdrivers; tighten down screws with torque wrench	
35	T-handle screwdriver, T 27 x 150	5910 890 2400	IS-P screws (4 mm)	1)

Remarks:

1) Use for releasing P screws only.

13. Servicing Aids

No.	Part Name	Part No.	Application
1	Lubricating grease (225 g tube)	0781 120 1111	Oil seals, oil pump drive, chain sprocket bearing, sliding and bearing points of brake band, pawl peg
2	STIHL multipurpose grease	0781 120 1109	
3	Ignition lead HTR (10 m)	0000 930 2251	
4	STIHL special lubricant	0781 417 1315	Bearing bore in rope rotor, rewind spring in fan housing
5	Dirko sealant, grey (100 g tube)	0783 830 2120	Engine pan, oil seals (outside)
6	Standard commercial solvent-based degreasant containing no chlorinated or halogenated hydrocarbons		Cleaning sealing faces
7	Medium-strength threadlocking adhesive (Loctite 242)	0786 111 1101	
8	High-strength threadlocking adhesive (Loctite 270)	0786 111 1109	
9	High-strength threadlocking adhesive (Loctite 649)	0786 110 0126	
10	STIHL Press Fluid OH 723 (50ml)	0781 957 9000	Installing annular buffers